

# RULES FOR THE 2021 HUMAN POWERED VEHICLE CHALLENGE COMPETITIONS

---

---



## **Table of Contents**

<b><i>General Information</i></b>	<b>6</b>
<i>Objective</i>	6
<i>Competition Summary</i>	6
<i>Superiority of Rules</i>	6
<i>Questions and Comments About the Competition and Rules</i>	6
<i>Location and Competition Information</i>	6
<i>Definitions</i>	7
<i>Schedule Summary &amp; Host Information</i>	8
<b><i>Suggested Reference Material</i></b>	<b>9</b>
<b><i>General Rules of Competition</i></b>	<b>10</b>
<i>Number of Vehicles to Compete</i>	10
<i>2021 Competitions</i>	10
<i>Modification of Design</i>	10
<i>Aerodynamic Devices</i>	10
<i>Team Number</i>	10
<i>Fairness of Competition</i>	10
<i>Protests</i>	11
<i>Event Scoring</i>	11
<i>Energy Storage Devices</i>	11
<i>Report and Video/Presentation Publication</i>	11
<i>Design Feedback</i>	11
<i>Readiness to Compete</i>	12
<b><i>Entry and Registration</i></b>	<b>12</b>
<i>Team Eligibility</i>	12
<i>Team Member Eligibility and Certification</i>	12
<i>Multiple Entries</i>	12
<i>Vehicle Design, Analysis, and Construction</i>	12
<i>Driver Requirement Exceptions</i>	12
<i>Late Vehicle Registration</i>	13
<i>Individual and Vehicle Registration fees</i>	13
<i>Refund of Registration Fees</i>	13
<i>Competition Information</i>	13
<i>On-Site Check-in</i>	13
<i>Late Check-in</i>	13
<b><i>Safety</i></b>	<b>14</b>
<i>General</i>	14

<b><i>Performance Safety Requirements</i></b>	<b>14</b>
<b><i>Minimum Braking System Requirement</i></b>	<b>14</b>
<b><i>Rollover Protection System</i></b>	<b>14</b>
<b><i>RPS Load Cases</i></b>	<b>15</b>
<b><i>RPS Attachment</i></b>	<b>16</b>
<b><i>Safety Harness</i></b>	<b>16</b>
<b><i>Custom Fabricated Harnesses</i></b>	<b>17</b>
<b><i>Testing requirements for non-commercially produced harnesses</i></b>	<b>17</b>
<b><i>Testing requirements for off application buckles</i></b>	<b>17</b>
<b><i>Vehicle Hazards</i></b>	<b>17</b>
<b><i>Critical Design Review Competition</i></b>	<b>18</b>
<b><i>Objective</i></b>	<b>18</b>
<b><i>Description</i></b>	<b>18</b>
<b><i>Critical Design Review Report</i></b>	<b>18</b>
<b><i>Critical Design Review Report Organization</i></b>	<b>19</b>
<b><i>Critical Design Review Report Content</i></b>	<b>19</b>
<b><i>CDR Report Cover Page</i></b>	<b>19</b>
<b><i>Title Page</i></b>	<b>19</b>
<b><i>3-View Drawing of Vehicle</i></b>	<b>19</b>
<b><i>Abstract</i></b>	<b>20</b>
<b><i>Design</i></b>	<b>20</b>
<b><i>Analysis</i></b>	<b>20</b>
<b><i>Conclusions</i></b>	<b>21</b>
<b><i>References</i></b>	<b>21</b>
<b><i>Appendices</i></b>	<b>21</b>
<b><i>Prior Work</i></b>	<b>22</b>
<b><i>Critical Design Review Report Submittal</i></b>	<b>22</b>
<b><i>Late Reports</i></b>	<b>22</b>
<b><i>Critical Design Review Presentation</i></b>	<b>22</b>
<b><i>Objective</i></b>	<b>22</b>
<b><i>Format</i></b>	<b>22</b>
<b><i>Time Limit</i></b>	<b>22</b>
<b><i>Content &amp; Scoring</i></b>	<b>22</b>
<b><i>Critical Design Review Scoring</i></b>	<b>23</b>
<b><i>CDR Score Penalties</i></b>	<b>23</b>
<b><i>Overall CDR Scoring</i></b>	<b>23</b>
<b><i>Innovation Competition</i></b>	<b>24</b>
<b><i>Description</i></b>	<b>24</b>
<b><i>Definition of Innovation</i></b>	<b>24</b>

<b>Report</b>	<b>24</b>
<b>Prior Work</b>	<b>25</b>
<b>Innovation Report Submittal</b>	<b>26</b>
<b>Late Reports</b>	<b>26</b>
<b>Innovation Presentation</b>	<b>26</b>
<b>Innovation Score Penalties</b>	<b>26</b>
<b>Scoring</b>	<b>27</b>
<b>Announcement of Results and Awards</b>	<b>28</b>
<b>Announcement of Results</b>	<b>28</b>
<b>Presentation of Awards</b>	<b>28</b>
<b>Competition Awards</b>	<b>28</b>
<b>Review and Modification of Results</b>	<b>28</b>
<b>Clarification and Modification of Rules</b>	<b>28</b>
<b>Clarification and Modification of the Rules</b>	<b>28</b>
<b>Questions and Comments About the Rules</b>	<b>28</b>
<b>Appendix 1: Critical Design Review Score Sheet</b>	<b>29</b>
<b>Appendix 2: Innovation Competition Score Sheet</b>	<b>30</b>
<b>Appendix 3: Protest Form</b>	<b>31</b>
<b>Appendix 4: CDR Report Cover Page</b>	<b>32</b>
<b>Appendix 5: Innovation Report Cover Page</b>	<b>33</b>

**ATTENTION E-FESTERS! Please read this important announcement about ASME E-Fests® in 2021**

ASME is excited to host an E-Fest Digital event in April 2021. E-Fest Digital will include career and professional development content, digital competitions (including the Human Powered Vehicle Challenge, the Student Design Competition, the Innovative Additive Manufacturing 3D Competition, the Oral Competition and the Elevator Pitch Competition) and much more! Additional details will be available soon. Questions may be directed to [efests@asme.org](mailto:efests@asme.org).

We encourage students, competitors, and faculty members to take advantage of the learning experiences provided by both our competitions and other digital offerings throughout the year. Questions may be directed to [efests@asme.org](mailto:efests@asme.org) and a digital calendar will be posted on <http://efests.asme.org> with lots of information.

All ASME conferences, meetings and events scheduled through December 2021 are being planned as virtual only, enabling everyone to enjoy the full benefits of participation via our virtual event solutions with no physical presence required. ASME will not have any physical or in-person events during this time but will continue to deliver the insights and expertise that our community depends upon. For more information about ASME's virtual approach to events and meetings, visit <https://www.asme.org/anywhere>.

Students are encouraged to download E-Fest competitions rules at <https://efests.asme.org/competitions> for our 2021 Digital events.

Additionally, ASME will be hosting a series of year-long digital events including a [Student & Early CareerTown Hall](#) (Sept. 17, 8:00 pm – 9:15 pm EDT), E-Fest Careers 2020 (November 7), webinars and other competitions. Please visit <http://efests.asme.org> for more details.

## I. **General Information**

### A) *Objective*

ASME's Human Powered Vehicle Challenge (HPVC) is an engineering design and innovation competition that gives students the opportunity to network and apply engineering principles through the design, fabrication and racing of human powered vehicles.

### B) *Competition Summary*

ASME and the ASME HPVC Committee will host two independent worldwide competitions in 2021: a Critical Design Review competition (online/digital) and an Innovation competition (online/digital). Students are encouraged to participate in one or both the competitions, but scores will remain separate between each competition. Scores from each competition will be used to determine the winner for that competition only.

Announcements about other competitions will be posted on <http://efests.asme.org>.

Each of the above competitions are described in detail in section III.B

### C) *Superiority of Rules*

These rules have been established by ASME's Human Powered Vehicle Challenge Committee. Should any conflict arise between these rules and those of the ASME, the ASME rules shall dominate. Should any conflict arise between these rules and other information regarding the ASME HPVC, whether generated by the ASME or any other organization, these rules shall dominate.

### D) *Questions and Comments About the Competition and Rules*

Questions about the competitions and rules must be posted on the HPVC Question Forum listed below.

### E) *Location and Competition Information*

Physical locations and Digital platforms for all competitions can be found on the official HPVC website. Teams wishing to participate should consult the HPVC website, ASME HPVC Community on Facebook, and HPVC Questions Forum.

Official HPVC Website:

[https://efests.asme.org/competitions/human-powered-vehicle-challenge-\(hpvc\)](https://efests.asme.org/competitions/human-powered-vehicle-challenge-(hpvc))

Official Rules and Forms:

[https://efests.asme.org/competitions/human-powered-vehicle-challenge-\(hpvc\)](https://efests.asme.org/competitions/human-powered-vehicle-challenge-(hpvc))

HPVC Facebook Community:

- <http://www.facebook.com/ASMEHPVC>
- <https://www.facebook.com/groups/ASMEHPVC>

HPVC Question Forum: <https://groups.google.com/g/asme-hpvc>

## F) Definitions

**Competition:** an individual HPVC hosted at a location physically (e.g. HPVC West) or digitally (eg. Critical Design Review)

**Event:** an element of the competition (e.g. Speed Event)

**Team:** a group competing in the competition consisting of a vehicle and team members

**Vehicle:** a single entry in a competition

**Individual:** a single participant of a competition and likely a team member

**Driver:** any individual who is or will be riding in a vehicle during a competition

**Competitor:** an individual who is competing in a specific event at a competition (ie driver, presenter, team member)

**Registration:** the process to collect fees and record individual and vehicle information by ASME

**Check-in:** the process and act of reporting an individual's and/or vehicle's presence at a competition

**Online/digital Event:** an event that will be held on a digital platform rather than meeting in-person at a physical location

**Live Event:** an event that will be held at a physical location requiring individual/team presence

**G) Schedule Summary & Host Information**

The ASME HPVC website shall specify all the important dates and contact information for the relevant competition.

Participation in the ASME HPVC competitions requires submission of materials in accordance with the schedule shown below. Please refer to the ASME HPVC website for exact dates, submission links, and registration instructions.

<b>Deliverable</b>	<b>Method of Submission and Format</b>	<b>Date Due</b>
<b>Critical Design Review</b>		
Critical Design Review Registration	Every team must register online via E-Fest website	30 days before Critical Design Review report deadline
Critical Design Review Report	Electronic submission via competition website	30 days before Critical Design Review Presentation
Critical Design Review Presentation	Online/digital	Winter/Spring 2021
<b>Innovation Competition</b>		
Innovation Registration	Every team must register online via E-Fest website	30 days before Innovation report deadline
Innovation Report	Electronic submission via competition website	30 days before Innovation presentation
Innovation Presentation	Online/digital	Spring 2021
<b>Protests</b>		
Protests (Appendix 3)	Submit to Head Judge only if required	In accordance with III.G



## II. Suggested Reference Material

Below are reference documents helpful in HPV design and construction. If your team references any of these sources please ensure they are properly cited in your report.

### Vehicle Design

1. [“The Recumbent Trike Design Primer”](#) (Rickey Horwitz, 2010). Basic pedal-powered tricycle design considerations, online.  
<https://pdfs.semanticscholar.org/5ee5/84368629fdc7ad69a3adf63da2c8e90de9f4.pdf>
2. [“Engineer to Win”](#) (Carroll Smith, 2010). Racing car design, paperback.  
<https://www.amazon.com/Engineer-Win-Carroll-Smith/dp/B011MBDQOM>
3. [“Race Car Vehicle Dynamics”](#) (William Milliken, 1994)  
<https://www.amazon.com/Race-Car-Vehicle-Dynamics-Premiere/dp/1560915269>

### Materials

1. [“Racer’s Encyclopedia of Metals, Fibers & Materials”](#) (Forbes Aird, 1994). Paperback.  
<https://www.amazon.com/Encyclopedia-Materials-Motorbooks-International-Powerpro/dp/0879389168>
2. [“Competition Car Composites”](#) (Simon McBeath, 2016). Composites design & fabrication handbook, hardcover.  
<https://www.amazon.com/Competition-Car-Composites-Practical-Handbook/dp/1845849051>

### Human Power and Bicycle

1. [“Sheldon Brown’s Bicycle Technical Info”](#) (Sheldon Brown). Bicycle design and reference guides  
<https://www.sheldonbrown.com/>
2. [“Design of Human Powered Vehicles”](#) (Mark Archibald, 2016). Extensive HPV discussion, hardcover.  
<https://www.amazon.com/Design-Human-Powered-Vehicles-Mark-Archibald/dp/0791861104>
3. [“Bicycling Science”](#) (David Gordon Wilson, 2004). Broad introductory cycling resource, paperback.  
<https://www.amazon.com/Bicycling-Science-Press-Gordon-Wilson/dp/0262731541>
4. [“The Biomechanics of Force and Power Production in Human Powered Vehicles”](#) (Danny Too, Gerald Landwer). Factors affecting power production via recumbent pedaling, online.  
[https://digitalcommons.brockport.edu/cgi/viewcontent.cgi?article=1100&context=pes\\_facpub](https://digitalcommons.brockport.edu/cgi/viewcontent.cgi?article=1100&context=pes_facpub)
5. [“Biomechanics of Cycling”](#) (Borut Fonda & Nejc Sarabon). Literature review of cycling biomechanics, online.  
<https://www.degruyter.com/downloadpdf/j/ssr.2010.xix.issue-1-2/v10237-011-0012-0/v10237-011-0012-0.pdf>
6. [“HPVC Safety Dos and Don'ts”](#) (Mark Archibald, 2016). HPV safety best practices.  
<https://community.asme.org/hpvc/w/wiki/13014.educational-resources.aspx#Safety-Dos-Donts>
7. [“Lords of the Chainring”](#) (William Patterson, 2012). Technical theory of the handling qualities of bicycles and motorcycles. Basis of a university course on single track vehicle design.  
<https://www.amazon.com/Lords-Chainring-William-Patterson-ebook/dp/B006W417OG>

### Critical Design Review

1. Design, Houghton. “How Do You Carry out an Effective Critical Design Review (CDR)?” *Houghton Design*, 5 Apr. 2019,  
[haughtondesign.co.uk/how-do-you-carry-out-an-effective-critical-design-review-cdr](http://haughtondesign.co.uk/how-do-you-carry-out-an-effective-critical-design-review-cdr).

If you have any suggestions for additional reference material please post it on the HPVC Question Forum.

### III. **General Rules of Competition**

#### A) *Number of Vehicles to Compete*

There may be a cap on the maximum number of teams at any competition. If so, it will be listed on the competition website at least 90 days before the competition. There is no requirement for a minimum number of vehicles. However, should the number of vehicles entered be more than one but less than four, the number of awards granted for overall placement in that competition shall be one less than the number of competing vehicles.

#### B) *2021 Competitions*

- Critical Design Review Competition (CDR) (Online/digital): Teams will be scored on their application of sound engineering principles and practices toward a vehicle design. The objective is to demonstrate design maturity without engaging in fabrication, assembly, or testing. This competition includes a written report and a technical presentation.
- Innovation Competition (Online/digital): Teams will be scored based on the specific design, concept evaluation, learnings, and analysis of the proposed innovation related to human powered vehicles. This competition includes a written report and a technical presentation.

#### C) *Modification of Design*

Modifications to the design are allowed between the report submission and the presentation for each competition. However, vehicles must retain their main frame and general drivetrain configuration after the submission of the competition report. Any vehicle deemed to have undergone significant changes in excess of this allowance should discuss the updates during the presentation.

#### D) *Aerodynamic Devices*

Vehicles may include components, devices, or systems engineered specifically to reduce aerodynamic drag. Front fairings, tail sections, full fairings, and other such devices are encouraged. The effectiveness of aerodynamic devices must be substantiated in the design report in order to receive credit for the design scores regarding aerodynamics.

Make-shift devices which are unrepresentative of the design, are crudely crafted, and/or present a clear safety concern will be prohibited, and must be removed prior to racing unless previously granted a waiver by the Head Judge. Fairing configurations may be changed between events in accordance with Section III.C provided that all safety requirements, including the seat belt and Rollover Protection System (RPS) rules, are not compromised by the change of configuration.

#### E) *Team Number*

The Head Judge will assign each team a number.

#### F) *Fairness of Competition*

All participating teams will be assured an equal opportunity and a fair competition. Any participating team that, in the reasoned opinion of the judges, seeks to exert an unfair advantage over other competitors will be subject to a penalty in performance points or disqualification from the competition.

G) *Protests*

Protests must be submitted in writing using the Protest Form available in the appendices. This form must be emailed by the team captain to [hpvcasme@gmail.com](mailto:hpvcasme@gmail.com) with the subject "Protest - <(CDR or Innovation)> - <team number>". Protest forms will be accepted upto 12 hours after the announcement of results unless otherwise allowed by the Head Judge.

Protests must be specific in nature and must include a factual account of the event being protested and the specific rules infraction, or the perceived error in the scoring of an event. Protests will be examined and resolved by the judges at their earliest convenience. Their decision will be communicated through email and will be final and without further appeal.

H) *Event Scoring*

Scoring for each event will be based on a points system. The team with the most points in an event wins that event. The team with the highest overall score from various events in that competition will become the overall winner of that competition.

I) *Energy Storage Devices*

Vehicles may employ the use of energy storage devices for purposes of accelerating and improving performance of their vehicles, but by no means are they required. If energy storage is used energy must be stored after the race has begun with human power as the sole external source of energy. Prior to each race, each team must demonstrate that their storage device has zero propulsive energy stored.

During the safety inspection the team must be prepared to discuss the safety of the storage device, especially during a high-speed incident. Teams whose vehicle presents an unacceptable risk in the perception of the judges will not be allowed to utilize the energy storage device in the competition.

Stored energy used to power non-motive systems (does not impart momentum to the vehicle) is allowed and may be stored prior to the beginning of the race.

Combustion engines are excluded from the competition.

J) *Report and Video/Presentation Publication*

After the completion of the annual competitions, all reports and submitted videos/presentations will be published to a shared website.

If a team does not want their report and/or video/presentation posted publicly, the team must submit a request, in writing, to the Head Judge no later than the submission deadline. The request must convincingly outline the grounds (such as active NDAs, or submission for intellectual property) for which the request is being made, and teams must be prepared to present an alternative submission omitting any specific sections in question. Requests will be granted or denied by the judges, and their decision will be final and without appeal.

K) *Design Feedback*

In an effort to help teams learn from their experience, the competition judges will be providing feedback on each team's performance in the Critical Design Review competition.

During the evaluation of the reports and presentations, the judges will take note of specific areas where teams may be able to most improve their scores. Judges will be looking for things like areas that may be missing key details, where teams missed the mark with information provided or just generally in what areas the team can improve the most. Feedback provided will be constructive and actionable so that teams will walk away with a better understanding of the scores they received and how they can improve their skills further.

Feedback will be available to teams digitally via time slots after the Critical Design Review competition. Teams desiring feedback can sign up for the time slots in advance of the feedback period. Further information regarding the feedback session will be communicated to the team captains.

L) *Readiness to Compete*

Teams must show up ready for presentations on time, with a stable internet connection, clear audio, and the ability to screen share.

IV. **Entry and Registration**

A) *Team Eligibility*

Entry in the Human Powered Vehicle Challenge is open to teams from any college or university in the world.

B) *Team Member Eligibility and Certification*

All members of the respective school's team must be enrolled as full-time students in any program of study at that school. Any individual that is currently a full-time student, enrolled for the next upcoming semester/quarter, or has been enrolled for the previous semester/quarter, but graduated no earlier than six months prior to the competition date, is eligible to fully participate in the ASME HPVC. The faculty advisor and team captain must be from the engineering department of the college or university.

All the teams must complete registration for all team members. A registered participant can be the captain of only one team for each competition.

C) *Multiple Entries*

Multiple teams are allowed from a single university provided that they have different team captains and team members. In other words, **no participant should compete in multiple entries for any single competition.**

D) *Vehicle Design, Analysis, and Construction*

The research, analysis, and design of all vehicles entered by a school must be performed solely by current eligible team members unless otherwise mentioned for that competition. All student team members shall be listed on the team's official report for that competition. Construction of the vehicle may include the assistance of outside vendors where the required capabilities exceed those available at the school.

E) *Driver Requirement Exceptions*

All racing events require that teams have at least one driver of each gender. Significant penalties are incurred for teams that do not meet this requirement, as described in the rules for each event. An exception to the eligibility rule may be granted to allow drivers to compete for a

school other than that in which they are enrolled, as described below. No other exceptions will be allowed.

If a participating school's roster cannot support at least one complete crew (group of drivers) including each gender, that school may request the voluntary participation of one or more drivers from volunteers in attendance provided that the volunteer 1) meets all eligibility requirements from section IV.B and 2) will not participate in the same event for any other team. The requester must submit a written request for a waiver of the rules for this purpose to the Head Judge for approval prior to the start of the applicable event. Scores derived in this manner will be credited to the requester.

*F) Late Vehicle Registration*

At its sole discretion, ASME may consider late vehicle registration after the entry date.

*G) Individual and Vehicle Registration fees*

The registration fees for the competition may differ depending on the competition. The specific fees and more information including where to direct your questions will be outlined on the competition and E-Fest websites (<https://efests.asme.org/>).

*H) Refund of Registration Fees*

Online registration for all competitions is managed by the ASME E-Fests staff. Requests for refunds should be made directly to them via the contact information on the ASME E-Fests website.

*I) Competition Information*

The following information, or a URL for a website that contains this information, shall be provided to each team:

- Team numbers
- List of deadlines for each competition
- Digital check-in location and time
- Submission forms for the reports, videos, and presentations
- Digital platform (if applicable) for hosting the competition
- A schedule of events (if applicable)
- A schedule of presentations (if applicable)

*J) On-Site Check-in*

All competitors must check-in digitally with ASME E-Fest and HPVC staff before participating in the competitions. Check-in location and time shall be provided to teams on the HPVC website.

*K) Late Check-in*

Late check-in will only be possible if prior arrangements have been made with the Head Judge, at least one week in advance of the competition start date.

## V. **Safety**

### A) *General*

The safety of participants, spectators, and the general public will override all other considerations during the competition. The judges will consider the safety features of the competition courses, as well as those of the competing vehicles, in permitting each event of the competition to begin or continue. Any event of the competition may be delayed, terminated prematurely, or canceled if the Head Judge, in consultation with ASME and the competition judges, determines that such action is necessary in the interest of safety.

CDR and Innovation event participants must base their designs in conformity to the safety rules.

### B) *Performance Safety Requirements*

Each vehicle must demonstrate that it can come to a stop from a speed of 25 km/hr in a distance of 6.0 m (19.7 ft), can turn within an 8.0 m radius (26.2 ft), and demonstrate stability by traveling for 30 m (98.4 ft) in a straight line at a speed of 5 to 8 km/hr (fast paced walking speed).

### C) *Minimum Braking System Requirement*

At a minimum each vehicle must have a braking system with properly designed brakes on the front most wheel of the vehicle. If multiple forward wheels are employed (such as in a tadpole trike or quad bicycle design) each wheel must have its own brake. Simply put, vehicles must at least have front brakes.

Even though teams may employ front brakes as outlined here teams are still responsible to conduct adequate testing to ensure that the vehicle can pass the stopping performance test outlined in the performance safety requirements.

### D) *Rollover Protection System*

All vehicles must include a rollover protection system (RPS) that protects all drivers in the vehicle in the event of an accident, unless the RPS makes the vehicle less safe. In that case, an exemption must be requested per section F. Functionally, the RPS must:

- Absorb sufficient energy in a severe accident to minimize risk of injury
- Prevent significant body contact with the ground in the event of a fall (vehicle moves from upright to resting on its side) or rollover (vehicle moves from upright to an inverted position)
- Provide adequate abrasion resistance to protect against sliding across the ground. This is particularly important around the driver's arms and legs. Adequate guarding must be included

The RPS must allow for a load path supporting the driver and retaining them from being ejected from the HPV in the event of a crash. This load path will be defined from the ground (impact point), to the outside of the vehicle body, through the structural RPS, through the safety harness, to the driver's body (center of gravity). A thorough RPS design includes the structural fortitude of not only the roll bar/frame, but also a rigidly mounted and structurally sound seat and properly affixed safety harness. In the RPS analysis teams must document the load path from driver to ground to receive full points.

In order to demonstrate the effectiveness of the RPS in protecting body contact from the ground teams may be required, during safety check, to lay their vehicle on its side as well as invert it

fully with the largest driver inside. Once laying on its side and inverted the driver must not make contact with the ground and if safety is compromised vehicle modifications will be required or the vehicle will not be allowed to race.

The RPS must be primarily a continuous hoop or truss, capable of withstanding all forces throughout a plausible rollover crash sequence, including reasonably likely forces not described in the load cases required for analysis & testing. Discrete cantilevered structural members oriented in directions of defined load cases are not acceptable. In order to participate in the competition, all RPS structural components (including the continuous hoop) must be physically tested or analyzed according to the top & side load requirements described below, and the results need to be presented in the CDR report and the presentation.

#### 1) RPS Load Cases

The RPS system shall be evaluated based on two specific load cases – a top load representing an accident involving an inverted vehicle and a side load representing a vehicle fallen on its side. **In all cases the applied load shall be reacted by constraints at the safety harness attachment points;** simulating the reaction force exerted by the driver in a crash.

- (a) Top Load: A load of 2670 N per driver/stoker shall be applied to the top of the roll bar(s), directed downward and aft (towards the rear of the vehicle) at an angle of 12° from the vertical, and the reactant force must be applied to the seat belt, seat, or roll bar attachment point and not the bottom of the roll bar (unless the bottom is the attachment point). Note that there may be one roll bar for the driver and another roll bar for the stoker which will result in each RPS having an applied load of 2670 N, or the driver and stoker can both be protected by a single roll bar which will result in the RPS having an applied load of 5340 N.

The roll bar is acceptable if 1) there is no indication of permanent deformation, fracture, or delamination on either the roll bar or the vehicle frame, 2) the maximum elastic deformation is less than 5.1 cm and shall not deform such that contact with the driver's helmet, head or body will occur.

- (b) Side Load: A load of 1330 N per driver/stoker shall be applied horizontally to the side of the roll bar at shoulder height, and the reactant force must be applied to the seat belt, seat, or roll bar attachment point and not the other side of the roll bar. Note that there may be one roll bar for the driver and another roll bar for the stoker which will result in each RPS having an applied load of 1330 N, or the driver and stoker can both be protected by a single roll bar which will result in the RPS having an applied load of 2670 N.

The roll bar is acceptable if 1) there is no indication of permanent deformation, fracture or delamination on either the roll bar or the vehicle frame, 2) the maximum elastic deformation is less than 3.8 cm and shall not deform such that contact with the driver's helmet, head occurs.

#### 2) RPS Attachment

The RPS must be structurally attached and braced to the vehicle frame or fairing and, with the vehicle in the upright position, must extend above the helmeted head(s) of the driver(s) such that no part of any driver will touch the ground in a rollover or fall over condition. The

RPS may be incorporated into the fairing, providing that part of the fairing is used in all events. Teams must demonstrate that the RPS meets both functional requirements and loading requirements. See Figure 1

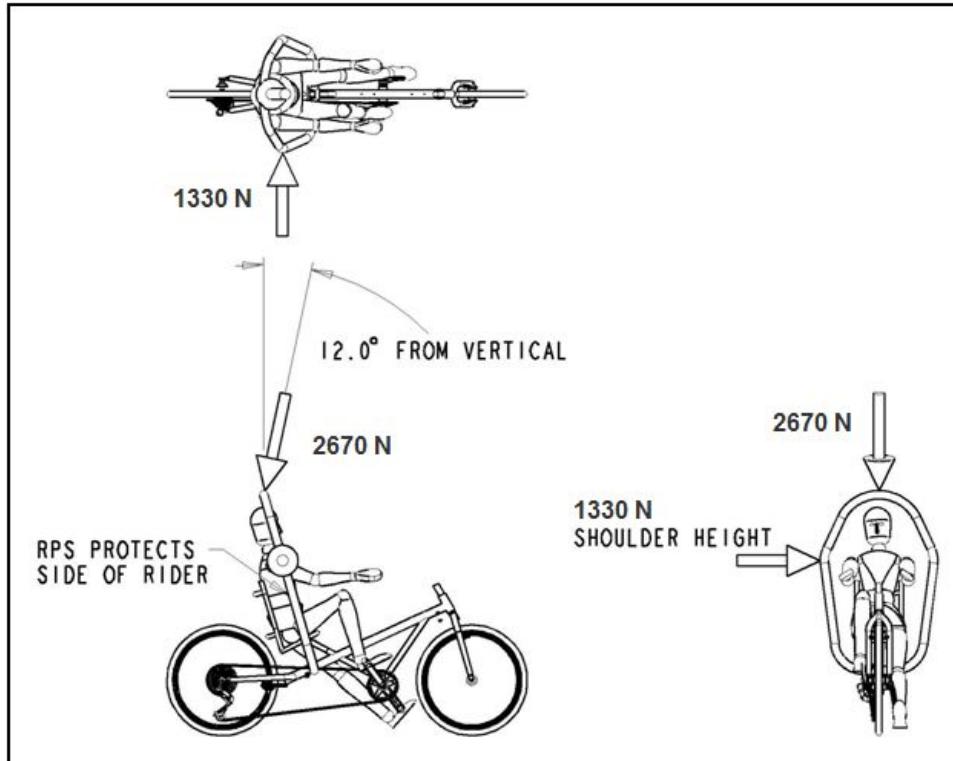

**Figure 1: Example of Proper RPS Design and Side and Top Load Case Applications (Note: Loads shown should not be applied concurrently in analysis and/or testing. Reaction loads should be applied at safety harness attachment points)**

E) *Safety Harness*

All drivers of all vehicles must be secured to their vehicle by **safety harnesses with lap and shoulder belts** (also known as 4 or 5 point safety harnesses) at all times that the vehicle is in motion, unless the safety harness makes the vehicle less safe. In that case, an exemption must be requested per section F. Lap belts or shoulder belts alone will not be sufficient and will require upgrading prior to racing. Commercially available harnesses designed for automotive, aviation or racing applications will generally be accepted without test data for the straps and buckles. Test data for attachment points may still be required at the time of the safety inspection.

Harnesses should be adjusted as firmly as possible, consistent with comfort, to provide the protection for which they have been designed. The safety harness must prevent any upward or forward motion of the driver's torso. Any slack in the harness must be adjusted by using the seat belt length adjuster. The safety harness must always be worn tight and fastened to prevent the driver from having free movement when the vehicle is in motion. Loose safety harness while riding the vehicle will be subjected to penalty for safety violation.

The safety harnesses must be attached to the RPS or a structural member in the RPS and may not be attached to the seat unless it is structurally integrated into the RPS.



### 1) Custom Fabricated Harnesses

If the harness is custom fabricated by the team or a commercial entity not in the business of producing harnesses or webbing products designed for use in life supporting applications (i.e. climbing, racing, automotive), significant test data will be required, as defined below.

- Hand stitching of webbing is not acceptable under any situation. Machine stitching will be acceptable with supporting test data.
- Webbing connections secured with a properly tied water knot will be accepted without test data.
- The minimum acceptable width for harness webbing is 25mm.

### 2) Testing requirements for non-commercially produced harnesses

- Tensile test samples of a stitched joint must be prepared in an identical manner to the intended production method including: Base webbing material, thread, stitching pattern and quantity.
- Tensile tests performed on a minimum of 5 samples must show a 95% statistical confidence of an ultimate strength in excess of 3340 N.

### 3) Testing requirements for off application buckles

- Off application is defined as a buckle designed for anything other than a life supporting applications (automotive, aviation, climbing, etc.). Other buckles designed for life supporting applications will be accepted without testing documentation.
- Plastic buckles of any type are not permitted.
- Tensile tests performed on a minimum of 5 samples must show a 95% statistical confidence of an ultimate strength in excess of 3340 N.

### F) *Vehicle Hazards*

All surfaces of the vehicle—both on the exterior and in the interior in the region of the driver(s) and in the access area—must be free from sharp edges and protrusions, open tube ends, screws protruding more than three threads, and other hazards. All drivetrain components, steering components, and wheels must be fitted with appropriate guards if within reach of the driver and must be designed and constructed so that they will not injure the driver in the event of an accident. All fasteners must be secured with a thread locking method (e.g., lock-tite, nylon locknuts, double-nut, castle nut).

## VI. **Critical Design Review Competition**

### A) *Objective*

To demonstrate the effective application of established principles and practices of design engineering to the development of the team's vehicle without engaging in fabrication, assembly or testing.

### B) *Description*

A successful CDR is based on the determination that the subsystem requirements, subsystem detailed designs, results of reviews, and plans for test and evaluation form a satisfactory basis for proceeding into system manufacturing and integration.

The CDR competition includes two parts:

1. Design report submitted in advance of the presentation (See I.G Schedule)
2. Design review presentation to the competition judges (See VI.I Presentations)

### C) *Critical Design Review Report*

The report should concisely describe the vehicle design and document the design, analysis, and results. The report should have the character of a professional engineering report and should be organized as described in Section VI.D.

Reports should emphasize clarity both in presentation and in the statement of results and conclusions. Photographs and drawings are encouraged where beneficial in documenting unique features of the design.

Design reports shall use 12 point Calibri font, single line spacing within paragraphs and double line spacing between paragraphs. Major headers shall be 14 point Calibri Bold, left justified. Margins shall be 1 inch top, bottom, left, and right. All figures and tables shall include a caption in 10 point Calibri italic font. Do not use watermarks and graphics that obscure text legibility.

Report writers should note that bulk is not a desirable feature; therefore, reports have a **20 page maximum limit**. (The limit includes the following sections: Design, Analysis, and Conclusion. Required Report Cover Page, the 3-view drawing, the abstract, and references will not be included in the page count. Penalties will be levied for exceeding the page limit (See Section VI.K). Additionally, judges will not consider any page beyond the 20th.

A copy of the judges score sheet is included in Appendix 1 of these rules. Teams are strongly encouraged to carefully read the score sheet prior to writing the design report.

Teams are expected to comply with ASME's Code of Ethics in the creation of their reports.

D) *Critical Design Review Report Organization*

The design report shall be organized as follows:

- |       |  |  |
|-------|--|--|
| I.    | CDR Report Cover Page (Refer Appendix 4)     | No page number   |
| II.   | Title Page                                   | No page number   |
| III.  | 3-View Drawing of Vehicle                    | No page number   |
| IV.   | Abstract                                     | Page i   |
| V.    | Table of Contents                            | Page ii  |
| VI.   | Design                                       | <b>Page 1, First page that counts towards the limit.</b>                 |
|       | a. Objective                                 |  |
|       | b. Background                                |  |
|       | c. Prior Work                                |  |
|       | d. Organizational Timeline                   |  |
|       | e. Design Specifications                     |  |
|       | f. Concept Development and Selection Methods |  |
|       | g. Description                               |  |
| VII.  | Analysis                                     |  |
|       | a. RPS Analyses                              |  |
|       | b. Structural Analyses                       |  |
|       | c. Aerodynamic Analyses                      |  |
|       | d. Cost Analyses                             |  |
|       | e. Other Analyses                            |  |
| VIII. | Conclusion                                   |  |
|       | a. Comparison – Design goals and analysis    |  |
|       | b. Evaluation                                |  |
|       | c. Recommendations                           | <b>Last numbered page, Last page that counts towards the page limit.</b> |
| IX.   | References                                   |  |
| X.    | Appendices                                   |  |

E) *Critical Design Review Report Content*

Content of each section should be in accordance with the design report score sheet (see Appendix 1).

a. CDR Report Cover Page

The first page should be the completed Report Cover Page, available in appendix 4.

b. Title Page

The title page should include the report title, team number (assigned by ASME), names of team members including contact information for two designated team members, and the name and contact information of the faculty advisor.

c. 3-View Drawing of Vehicle

Include a drawing of the complete vehicle with at least front, top, and side projections. Key dimensions such as wheelbase, track, overall length and overall width should be included. Drawings to follow ASME Y14.5 and related standards such as ASME Y14.24 and ASME Y14.3

d. Abstract

The abstract should give a clear summary of the objectives, scope, and results of the vehicle design. It should be limited to no more than 300 words.

e. Design

The Design section should include an overall description of the vehicle with appropriate background information, design objectives, design criteria, and design alternatives that were considered. It should clearly demonstrate that established design methodologies, including structured design methods and engineering principles, were effectively used during the vehicle design process. Sub-sections include:

**Objectives:** Clearly state the objectives and design mission of the vehicle

**Background:** Include supporting research and review of prior art. Provide background information to justify your objectives, mission, design approaches, and design concepts. Background research should include specific information found/used to aid in design and development of the HPVC, but should not include your team's general competition history. Appropriate background research can include information found on HPV development, aerodynamics, HPV standards (such as ISO or Federal), competitive vehicles, etc. Cite references as appropriate.

**Prior Work:** Clearly document any design that was not completed in the current academic year. Only new, original content will be judged in both the critical design report and presentation. If teams reuse work from previous years and it is not listed here teams will be assessed a penalty for reusing content.

**Organizational Timeline:** Include an organizational timeline or Gantt chart showing project scheduling and completion.

**Design Specifications:** Provide the design specifications for the vehicle. Tables and bullets may be used. Also provide rationale or justification for the specifications as appropriate. Document methods (such as QFD) used to develop the specifications.

**Concept Development and Selection: Methods** Document the use of established concept development and selection tools such as the Pugh's Concept Selection Technique, etc.

**Description:** Describe the final vehicle design, making generous use of drawings and figures. Describe how the vehicle can be practically used, what environmental conditions (weather, etc.) were addressed and how components and systems were selected or designed to meet the stated objectives.

f. Analysis

The analysis section summarizes the engineering evaluation of the vehicle's performance and structural viability as related to the design criteria outlined in the description. **For each analysis documented, the objective, modeling method & assumptions, results, and conclusions should be clearly indicated.** Conclusions should describe how the results were used to improve the vehicle, i.e. what changes were made as a result of the analysis.

Each sub-section should include a table summarizing all analyses completed in that section. The summary should include objectives, methods, and results. In addition, provide selected examples of specific analyses in sufficient depth to allow judges to evaluate the technical correctness of the analysis. The analysis section should include the following subsections.

**RPS Analysis:** Document the structural analysis of the rollover and side protection system. This section must convincingly demonstrate that the RPS is fully compliant with Section V.D of these rules in order to obtain full points.

**Structural Analysis:** Document structural analyses conducted on the frame or mechanical components. Specify objectives, load cases, methods, and results. FEA is an appropriate tool, but not the only tool, used for structural analyses.

**Aerodynamic Analysis:** Document aerodynamic analyses, including drag estimates, conducted on fairings, aerodynamic devices, or other components. CFD is an appropriate tool for aerodynamic analyses.

**Cost Analysis:** Provide a tabulated cost analysis of the HPV. The cost analysis should include capital investment, tooling, parts and materials, and 3<sup>rd</sup> party labor costs, but not student labor costs.

**Other Analysis:** Document other analyses conducted during the design process, including power/speed modeling, vehicle handling, stability, steering, suspension kinematics & dynamics, optimizations, etc.

**Note: Physical testing and/or experiments will not be scored in the Critical Design Review Competition.**

g. Conclusions

Demonstrate that the design team completed a substantive evaluation of the vehicle design. This section should include the following subsections:

**Comparison:** Use a table to compare the vehicle design specifications with analytical performance predictions. Were design objectives met?

**Evaluation:** Describe how the final vehicle was evaluated with respect to the objectives and design specifications.

**Recommendations:** Document any recommendations for future work on the vehicle, including but not limited to modifications and improvements.

h. References

Citations must be provided for all non-original content. Citations should be formatted in the IEEE Citation Style or similar scientific citation style.

i. Appendices

Appendices could contain supplementary material that is not an essential part of the report itself but it would be helpful in providing a more comprehensive understanding of your work. it

could also contain information that is too cumbersome to be included in the report. **This section of the report will not be scored.**

F) *Prior Work*

**Credit will only be given for work (design and analysis) done during the current academic year.** The report should clearly indicate if work consists of improvements to a previous design. To be considered a new design, the vehicle must be substantially different from previous or additional entries (in the event a school is submitting multiple entries into a single competition) by that team or school. It is acceptable to advance and refine the design of an existing vehicle, but the new developments must be clearly differentiated from prior work.

Scoring is based solely on the current year's work and design points will not be awarded for design work done in previous academic years. It is acceptable to use off the shelf (stock) components and/or you can reuse components from previous year's vehicles, but will not receive any design points.

Unoriginal content, including content generated from other teams or previous years and not cited, may be assessed a penalty for plagiarism.

G) *Critical Design Review Report Submittal*

The Critical Design Review report must be submitted electronically as a PDF via a link on the competition website. See section I.G for the submission deadline.

H) *Late Reports*

Reports will be accepted up to two weeks before the competition presentation date, and subject to a penalty per day the report is late. Teams that do not submit reports within two weeks after the report due date will not be eligible for participation in the CDR presentation.

I) *Critical Design Review Presentation*

a. Objective

The design presentation gives teams an opportunity to present the design methodologies, including structured design methods and engineering principles which were effectively used during the vehicle design process. The presentation should focus on the considered design alternatives, design challenges and solutions adopted by the team. The presentation is also an opportunity to discuss any updates following the report submission.

b. Format

The presentation will be hosted on a digital platform in live format. The schedule of presentations will be shared one week before the presentation date. Other teams are encouraged to watch as many presentations as they wish.

c. Time Limit

Design presentations will have a maximum time limit of 12 minutes followed by a maximum of 3 minutes of questions from the judges.

d. Content & Scoring

Presentations will be scored by the same judges who scored the submitted CDR reports. For breakdown of presentation scoring please refer to CDR score sheet in Appendix 1.

J) *Critical Design Review Scoring*

Scoring is based on the extent to which established engineering design principles were applied in the design process and the effectiveness of the design practices used. Scores will also reflect the effectiveness of the report and presentation in communicating the design process and solution. Design teams must address each of the specified topics in order to receive a score for that topic. CDR scoring for all teams shall be as shown below:

<b>Subject Area</b>	<b>Maximum Points</b>
General	5
Design	15
Analysis	25
Presentation Delivery	10
<b>Total</b>	<b>55</b>

K) *CDR Score Penalties*

In addition to those previously described, penalties may be imposed by the competition judges for failures to comply with the rules of the CDR competition. Penalties will be assessed according to the following table in cases where an unfair advantage might have been gained or the Judges' ability to evaluate a design has been compromised.

<b>Rules Infraction</b>	<b>Maximum Penalty</b>
Report content largely non-original	Disqualification
Late report submittal	7% per day (Maximum of 100%)
Over Page Limit	3% Per Page
Report does not conform to required outline	10%
Report Cover Page & Vehicle Description	5%
Form missing from 1 <sup>st</sup> page or incomplete	1 point per page
Presentation over time limit	10%

L) *Overall CDR Scoring*

The judges will compile the CDR scores including any penalties on a total points basis. The competition score is given by

$$Points = \left( \frac{Team\ Raw\ Score}{Maximum\ Possible\ Raw\ Score} \right) \times 100$$

Where the Maximum Possible Raw Score is the maximum points possible according to the Judge's Score Sheet.

The team with the highest overall score will become the winner of the CDR competition. In the case of a tie, the CDR report scores will determine the overall finish.

## VII. Innovation Competition

### A) Objective

- 1) To encourage innovation that advances the state of the art in human powered vehicles
- 2) To provide teams an opportunity to demonstrate significant technological innovations

### B) Description

The Innovation competition includes two parts:

1. Innovation report submitted in advance of the competition (See I.G Schedule)
2. Innovation presentation delivered to a panel of judges (See VII.H Presentation)

This competition provides teams an opportunity to present a documented functional demonstration of a key innovative feature of the design that advances the technology of human powered vehicles. The innovation may be related to vehicle systems, performance, manufacturing methods, safety or other vehicle areas. Though participants may implement as many innovative features as they chose, **only one innovation may be selected to be scored in the innovation competition.** Innovation is a process and cannot be executed with a single iteration, therefore teams will be awarded significant points for the process of developing their innovation including prototyping and documenting their learnings. An overall score multiplier will be granted based on the novelty and difficulty/depth of the innovation challenge. Teams provide a detailed description of their innovation in their innovation report which is to be submitted before the innovation presentation. The innovation will be scored on design, concept evaluation (prototyping, analysis, or simulation), learning, and execution. Please refer to appendix 2 for the Innovation score sheet.

### C) Definition of Innovation

- 1) Innovation is the introduction of a previously unknown, unusual, or unfamiliar product, process, material or method, or the alteration of an established product, process, material or method by introducing new elements, forms or processes.
- 2) Innovations related to any aspect of human-powered vehicles are encouraged, including vehicle performance, manufacturing & materials, human physiology, safety, and ergonomics.

### D) Report

Teams shall submit an Innovation Report. The Innovation Report is due 30 days before the innovation presentation. A copy of the judges score sheet is included in Appendix 2 of these rules. Teams are strongly encouraged to carefully read the score sheet prior to writing the innovation report. The report should be no more than **20** pages in length, but must include a title slide and should contain the following sections:

- 1) Innovation Report Cover Page - refer Appendix 5 (No page number)
- 2) Title Page (No page number)
- 3) *Design* **First page that counts towards page limit**
  - (a) New Idea (score multiplier)- Students must provide clear evidence that they have developed a truly innovative and new idea. This can be bolstered by a high level of difficulty/depth of the innovation, and conversely trivial/banal innovations will not earn a high multiplier.



- (i) Previous examples of a high level of difficulty or depth in innovations include manufacturing methods for improving material properties in composite layups, active safety features (such as airbags), alternative storage (such as ultra-capacitor) or regenerative braking energy storage.
- (ii) Examples of a low level of difficulty or depth in innovations include some typical designs like a solar powered USB charger, a tool storage solution, or an integrated GPS or communication system.
- (b) Need- Describe the need addressed by this innovation. Why is it significant?
- (c) Advancing the Art of HPVs- Students must clearly show that the innovation has benefits, which can be performance, ergonomics, cost, environmental, social, etc.
- (d) Technology and Concept Feasibility Study- Students must clearly demonstrate that the innovation is feasible, and does not require a violation of the laws of physics or the use of an unavailable process or material. Students must also show that the proposed embodiment of the design is feasible. In other words, will the concept work?
- 4) Concept Evaluation- Note: **A prototype, analysis, or simulation can meet the requirements of concept evaluation. A prototype is recommended but not required if circumstances prevent it.**
  - (a) Functionality Evaluation- Does the prototype, analysis, or simulation show the intended purpose of the innovation? This is not an evaluation of how well it performs, but a validation of the design concept.
  - (b) Benefit Study- Students must provide data to show how effectively the **prototype, analysis, or simulation** achieved the anticipated benefits in question 3.c
  - (c) Unanticipated Benefits- Students must provide data to show how effectively the **prototype, analysis, or simulation** achieved unanticipated benefits. Often the proposed benefits are not as important as unanticipated benefits.
- 5) Learnings
  - (a) Failures- Students should document what did not work -- concepts that turned out to be infeasible (why?), **prototype, analysis, or simulation** that did not work (why?), and unanticipated difficulties.
  - (b) Learning from Failure- Students should document how failures were used as stepping stones to subsequent successes.
  - (c) Negative Aspects of the Design- Students should clearly identify and if possible quantify unanticipated negative aspects -- increased cost, regulatory restrictions, negative environmental aspects, etc.
- 6) Conclusions **Last page that counts towards page limit**
- 7) References- List all references and patents cited in the literature review

E) *Prior Work*

**Credit will only be given for work done during the current academic year.** The report should clearly indicate if work consists of improvements to a previous design. To be considered a new innovation, the submission must be substantially different from previous or additional entries (in the event a school is submitting multiple entries into a single competition) by that team or school. It is acceptable to advance and refine an innovation, but the new developments must be clearly differentiated from prior work. Scoring is based solely on the current year's work and points will not be awarded for work done previously.

Unoriginal content, including content generated from other teams or previous years and not cited, may be assessed a penalty for plagiarism.

F) *Innovation Report Submittal*

The innovation report must be submitted electronically as a PDF via a link on the competition website. See section I.G for the submission deadline.

G) *Late Reports*

Reports will be accepted up to two weeks before the competition presentation date, and subject to a penalty per day the report is late. Teams that do not submit reports within two weeks of the report date will not be eligible for participation in the Innovation presentation.

H) *Innovation Presentation*

- a. Objective The innovation presentation is an opportunity to demonstrate the functionality of each team’s final innovation prototype, analysis, or simulation, and any evaluation & learnings that have been found. The presentation is also an opportunity to discuss any updates following the report submission.
- b. Format The presentation will be hosted on a digital platform in live format. The schedule of presentations will be shared one week before the presentation date. Other teams are encouraged to watch as many presentations as they wish.
- c. Time Limit The innovation presentation will have a maximum time limit of 7 minutes followed by a maximum of 3 minutes of questions from the judges.
- d. Content & Scoring Presentation will be scored by the same judges who scored the submitted innovation reports. Teams will showcase any changes and learnings, but most importantly teams will demonstrate the efficacy of their final innovation by which the judging team will be able to evaluate its performance. For breakdown of presentation scoring please refer to the Innovation score sheet in Appendix 2.
- e. Formatting & Evidence Teams may dictate the method/structure through which the demonstration and results data is conveyed in the presentation, but at a minimum teams must show an unobstructed and unedited view of the innovation functioning to its best ability.
- f. Presentation Submission & Publication The Innovation presentation will be submitted to an official ASME HPVC database (a link will be posted to the competition website to submit the file). Following the same protocol as the written reports, after completion of the competition, presentation will be made public for the betterment of the HPVC as a whole.

I) *Innovation Score Penalties*

In addition to those previously described, penalties may be imposed by the Judging Team for failures to comply with the rules of the Innovation Competition. Penalties will be assessed according to the following table in cases where an unfair advantage might have been gained or the Judges' ability to evaluate a design has been compromised.

**Rules Infraction**

Report content largely non-original

**Maximum Penalty**

Disqualification

Late report submittal	7% per day (Maximum of 100%)
Over Page Limit	3% Per Page
Presentation over time limit	10%
Report does not conform to required outline	10%
Innovation Report Cover Page missing from 1 <sup>st</sup> page or incomplete	5%

J) *Scoring*

Teams will be scored out of 33 possible base points and an overall score multiplier, based on the following criteria:

- 1) Points are awarded based on the following areas
  - (a) Multiplier                    1x to 2x multiplier
  - (b) Design                        7 points
  - (c) Concept Evaluation        8 points
  - (d) Learnings                    7 points
  - (e) Execution                    6 points
  - (f) Presentation Delivery    5 points

Scoring breakdowns are detailed in the innovation score sheet document which can be found in Appendix 2 of these rules

- 2) Score in the Innovation Competition is the total points earned divided by the total possible points, expressed as a percentage:

$$Points = \left( \frac{Team\ Raw\ Score}{Maximum\ Possible\ Raw\ Score} \right) \times 100$$

Where the Maximum Possible Raw Score is the maximum points possible according to the Judge's Score Sheet.

The team with the highest overall score will become the winner of the Innovation competition. In the case of a tie in the overall point count, the Innovation report scores will determine the overall finish.

**VIII. Announcement of Results and Awards**

*A) Announcement of Results*

The judges will post the results of each competition within 2 weeks after the completion of the respective competition and validation of the collected data.

*B) Presentation of Awards*

The awards presentation will be held after the completion of the competition's final competition.

*C) Competition Awards*

Competition awards shall be given as follows:

Critical Design Review Competition	1 <sup>st</sup> + cash prize , 2 <sup>nd</sup> and 3 <sup>rd</sup> place awards
Innovation Competition	1 <sup>st</sup> + cash prize , 2 <sup>nd</sup> and 3 <sup>rd</sup> place awards

Minimum requirements are valid non-zero scores.

*D) Review and Modification of Results*

If an error or discrepancy is determined in the final results, it will be addressed by the competition judges as quickly as possible. To assure scoring accuracy is maintained, the competition judges will expedite every effort to resolve errors and reserves the right to review the results for up to 48 hours after the official awards ceremony to ensure all scores are accurate and final.

**IX. Clarification and Modification of Rules**

*A) Clarification and Modification of the Rules*

These rules may be modified by the Competition Judges as necessary to maintain the competition as a challenging and rewarding experience for engineering students. No changes by any party shall be made without the written consent of the Global Chief Judge. Questions or recommended changes should be referred through email ([hpvcasme@gmail.com](mailto:hpvcasme@gmail.com)) to the Global Chief Judge.

*B) Questions and Comments About the Rules*

Questions and comments about the rules must be posted on the HPVC Question Forum.

## X. Appendix 1: Critical Design Review Score Sheet

<b>CDR Evaluation</b>	<b>55</b>	
<b>General</b>	<b>5</b>	<b>Evaluated based on report</b>
<b>1 Form 6</b>	1	ASME Report Cover Page & Vehicle Description completed and attached to front of report
<b>2 Title Page</b>	1	Title page information correct and complete
<b>3 3-View Drawing</b>	1	3-View drawing, in accordance with ASME Y14.5 and related standards such as ASME Y14.24 and ASME Y14.3
<b>4 Abstract</b>	2	Abstract included, correct length, clear, concise, and informative. This should be page 1
<b>5 Design</b>	<b>15</b>	<b>Evaluated based on report and presentation</b>
<b>a New Design</b>	2	2 - Teams must demonstrate that the entry is a new design (not just a new frame or fairing) completed during the current academic year, or not HPVC entry for last 2 years 1 - Some new elements (frame, fairing, etc.) or no HPVC entry for last year 0 - Similar to previous year's entry
<b>b Design Methodology</b>		
Design Objective	1	Provide clear design objectives and goals for the project. (Hint: "To Win" or "To do better than last year" are not acceptable objectives)
Background research	1	Include supporting research and review of prior art. Provide background information to justify your objectives, mission, design approaches, and design concepts. Background research should include specific information found/used to aid in the design and development of the HPVC, but should not include your team's general competition history. Appropriate background research can include information found on HPV development, aerodynamics, HPV standards (such as ISO or Federal), competitive vehicles, etc. Cite references as appropriate.
Prior Work	1	Clearly document any design, fabrication, or testing that was not completed in the current academic year. If teams reuse work from previous years and it is not listed here teams will be assessed a penalty for reusing content.
Organizational Timeline	1	Include an organizational timeline or Gantt chart showing project scheduling and completion
Design Criteria/PDS	1	Provide well established design criteria and product design specifications
Alternatives and Evaluation	2	Present alternative designs that were considered using concept improvement and selection techniques
Structured Design Methods	1	Document use of established design methodologies, including, but not limited to QFD, Decision Matrices, etc. How did you choose features of your design with respect to your specifications and requirements?
Description	1	Describe the final vehicle design, making generous use of drawings and figures. Describe how the vehicle can be practically used, what environmental conditions were addressed and components and systems were selected or designed to meet the objectives.
<b>c Discretionary Points</b>	4	Discretionary points based on overall thoroughness, quality, accuracy, and approach
<b>6 Analysis</b>	<b>25</b>	<b>Evaluated based on report and presentation</b>
<b>a Rollover/Side Protection System</b>		Per RPS requirements
Top Load Modeling	1	Clearly and accurately describe constraints, idealizations, load path from driver to ground, etc.
Top Load Results	2	Clearly describe and interpret results, score depends on results and perceived validity of results. Target load is to be applied and deflection value is to be clearly documented as result. 0: Maximum total elastic deflection equal to or greater than 7.6 cm (3.0 in); 1: 6.4 cm (2.5 in); 2: 5.1 cm (2.0 in) or less
Side Load Modeling	1	Clearly and accurately describe constraints, idealizations, load path from driver to ground, etc.
Side Load Results	2	Clearly describe and interpret results, score depends on results and perceived validity of results. Target load is to be applied and deflection value is to be clearly documented as result. 0: Maximum total elastic deflection equal to or greater than 6.4 cm (2.5 in); 1: 5.1 cm (2.0 in); 2: 3.8 cm (1.5 in) or less
<b>b Structural Analytical Calculations</b>		Demonstrated appropriate and correct use of numerical computational tools such as FEA, CFD, etc.
Objectives	1	Clear objective for the analysis
Analysis Case Definitions	1	Clearly identify and describe analysis cases, include rationale for each
Modeling	1	Clearly and accurately describe constraints, idealizations, use of symmetry, etc.
Results	2	Clearly describe and interpret results
Design Modifications	1	Demonstrate how results were used to modify and improve the design
<b>c Aerodynamics</b>		
Aero Device Incorporated	1	All entries are required to have an aerodynamic device incorporated into their design (makeshift items, false claims, and claims such as reclined driver position contributes to aero will not be granted credit)
Alternatives Evaluated	1	Must evaluate several alternatives in a trade study
Chosen Design Substantiated	1	Must substantiate chosen aero device through analysis
<b>d Cost Analysis</b>		
	2	Tabulated cost summary of prototype included. Include all actual expenditures and capital costs, but do not include student labor.
<b>e Other Analyses</b>		Vehicle handling, stability, steering, suspension kinematics & dynamics, optimizations, and other analyses
Objectives	1	Clear objective for the analysis
Analysis Case Definitions	1	Clearly identify and describe analysis cases, include rationale for each
Results	1	Clearly describe and interpret results
Design Modifications	1	Demonstrate how results were used to modify and improve the design
<b>f Discretionary Points</b>	4	Discretionary points based on overall thoroughness, quality, accuracy, and approach
<b>7 Presentation Delivery</b>	<b>10</b>	<b>Evaluated based on CDR Presentation</b>
<b>a Organization</b>	2	Information is presented clearly in a logical sequence which can be easily followed
<b>b Content</b>	2	Presentation contains accurate and original information with sufficient evidence to support the claims
<b>c Creativity</b>	2	Demonstrate creativity through usage of visual aids and presentation of material in interesting/unique ways
<b>d Speaking Skills</b>	2	Demonstrates confidence through clear articulation, rhythm and tone without reading the slides
<b>e Subject Knowledge</b>	2	Presenter demonstrates full knowledge and can answer and elaborate on most/all questions

## XI. Appendix 2: Innovation Competition Score Sheet

2021 HPVC Innovation Scoring Criteria				
No.	Question	Points	Discussion	Notes
<b>Innovation Multiplier</b>				
1.	Is the proposed innovation a new idea?	1x to 2x multiplier	Students must provide clear evidence that they have developed a truly innovative and new idea. This can be bolstered by a high level of difficulty/depth of the innovation, and conversely trivial/banal innovations will not earn a high multiplier.	List/discussion of similar patents, summary of literature review, and/or patent applications by teams are sufficient. Reused innovations are <b>not acceptable</b> and points are only awarded in the first year a team submits a specific design. Ignorance of an existing design does not warrant allocation of points if the judging team does not feel the innovation is not a new idea.
<b>Design</b>				
1.	What is the need for the proposed innovation?	2	Students must document the target market and need of their specific innovation	All innovations solve problems for specific needs. Please list the embodiment of the need and how this innovation solves the problem.
2.	Does the proposed innovation benefit or advance the state of the art of human-powered vehicles?	2	Students must clearly show that the innovation has benefits, which can be performance, ergonomics, cost, environmental, social, etc.	This can be applicable in the HPVC or to mainstream human powered vehicles.
3.	Is the innovation possible with existing or proposed technology and is this specific proposed execution feasible?	3	Students must clearly demonstrate that the innovation does not require a violation of the laws of physics or the use of an unavailable process or material. Students must also show that the proposed embodiment of the design is feasible. In other words, the concept will work?	
<b>Concept Evaluation</b>				
1.	Is the prototype functional?	3	Does the prototype do what was intended? This is not an evaluation of how well it performs, but a validation of the design concept.	Early prototypes will often show more learning opportunities while subsequent prototypes (or iterative improvements to one prototype) will often better confirm functionality.
2.	Are the proposed benefits of the concept realized?	3	Students must provide data to show how effectively the prototype achieved the anticipated benefits in question 3.	This can be executed by testing a mock up, prototype, or even a full scale version.
3.	Are there any unanticipated benefits?	2	Students must provide data to show how effectively the prototype achieved unanticipated benefits. Often the proposed benefits are not as important as unanticipated benefits.	Often times during the innovation process unanticipated benefits outweigh the original goals of the design and advance the state of the art significantly.
<b>Learnings</b>				
1.	What failures were experienced?	2	Students should document what did not work -- concepts that turned out to be infeasible (why?), prototypes that did not work (why), and unanticipated difficulties.	Read Henry Petroski to get an idea of how important failures are in innovation.
2.	What was learned from the failures?	3	Students should document how failures were used as stepping stones to subsequent successes.	Most innovations are built on what is learned by failures. In fact, more is learned from failures than from successes.
3.	What are the unanticipated negative aspects of the design?	2	Students should clearly identify and if possible quantify unanticipated negative aspects -- increased cost, regulatory restrictions, negative environmental aspects, etc.	Even though benefits are realized, the innovation may not have full value because of some unanticipated negatives.
<b>Execution</b>				
1.	How well does the concept function based on the quality of the design?	3	Students should demonstrate how well the concept performs based on the quality of the design and the quality of physical execution	Well executed designs that function as intended shall receive maximum points, whereas poorly executed concepts with low craftsmanship that do not function shall receive low points.
2.	Does the quality of execution reinforce the benefit(s) of the innovation?	3	Students must show that the physical execution of the design allows for or exceeds the intended benefits of the innovation	If the execution of the concept performs up to or beyond the intended level described in the benefits, full points should be awarded. If explicit metrics for measuring the quality of execution are not available the judges will assess points at their discretion.
<b>Presentation Delivery</b>				
1.	Organization	1	Information is presented clearly in a logical sequence which can be easily followed.	
2.	Content	1	Presentation contains accurate and original information with sufficient evidence to support the claims.	
3.	Creativity	1	Demonstrate creativity through usage of visual aids and presentation of material in interesting/unique ways.	
4.	Speaking Skills	1	Demonstrates confidence through clear articulation, rhythm and tone without reading the slides.	
5.	Subject Knowledge	1	Presenter demonstrates full knowledge and can answer and elaborate on most/all questions.	

XII. Appendix 3: Protest Form

	<p><b>PROTESTS Form</b> <b>Human Powered Vehicle Challenge</b></p> <p><b>Competition Name:</b> _____</p> <p><b>Competition Location:</b> <u>Digital</u></p> <p><b>Competition Date:</b> _____</p>
<p><b>*** This is <u>NOT</u> a required form. It may be used <u>only if</u> a team is filing a protest during a competition ***</b> <b>Additional details can be found in the Rules, Section III.G.</b> <b>***</b></p>	

**Protests**

Protests may be made in accordance with the rules of the ASME Human Powered Vehicle Challenge. This protest format may be used or not used at the discretion of the team or individual presenting the protest. If this format is not used, the information outlined herein should be included in whatever format is used.

This form must be emailed to [hpvcasme@gmail.com](mailto:hpvcasme@gmail.com) with the subject "Protest - <(CDR or Innovation)> - <team number>". Protest forms will be accepted up to 12 hours after the announcement of results unless otherwise allowed by the Head Judge. Oral protests will not be honored.

Date: \_\_\_\_\_ Protestor's Vehicle No: \_\_\_\_\_  
Protesting School: \_\_\_\_\_  
Other Vehicle(s) Involved (if applies): \_\_\_\_\_

Event during which protested action occurred: \_\_\_\_\_  
Nature of protest (e.g., rule violation, error in scoring, etc.): \_\_\_\_\_

Description of incident/statement of protest

---

---

---

---

---

---

---

---

---

---

XIII. Appendix 4: CDR Report Cover Page

	<p><b>Critical Design Review Report Cover Page &amp; Vehicle Description Form</b> <b>Human Powered Vehicle Challenge</b> <b>Competition Location: <u>Digital</u></b> <b>Competition Date: _____</b></p>
<p><i>This required document for <u>all</u> teams is to be incorporated into your Critical Design Review Report. Please Observe Your Due Dates; see the ASME HPVC website and rules for due dates.</i></p>	

**Vehicle Description**

University name:

Vehicle name:

Vehicle number:

Vehicle configuration:

Upright

Semi-recumbent

Prone

Other (specify)

Frame material:

Fairing material(s):

Number of wheels:

Vehicle Dimensions (m)

Length:

Width:

Height:

Wheelbase:

Weight Distribution (kg)

Front:

Rear:

Total Weight (kg):

Wheel Size (m)

Front:

Rear:

Frontal area (m<sup>2</sup>):

Steering (Front or Rear):

Braking (Front, Rear, or Both):

Estimated Coefficient of Drag:

Vehicle history (e.g., has it competed before? where? when?):



**XIV. Appendix 5: Innovation Report Cover Page**

 <p>ASME SETTING THE STANDARD</p>	<p><b>Innovation Report Cover Page &amp; Innovation Description Form</b> <b>Human Powered Vehicle Challenge</b> <b>Competition Location: <u>Digital</u></b> <b>Competition Date: _____</b></p>
<p><i>This required document for <u>all</u> teams is to be incorporated into your Innovation Report. <u>Please Observe Your Due Dates</u>; see the ASME HPVC website and rules for due dates.</i></p>	

University name:

Vehicle number:

Innovation title:

Innovation summary (Upto 150 words):