



energy | innovation | sustainability | engineering | design

# RULES FOR THE 2020 HUMAN POWERED VEHICLE CHALLENGE

---

---



## **Table of Contents**

<b>General Information</b>	<b>7</b>
<i>Objective</i>	7
<i>Superiority of Rules</i>	7
<i>Questions and Comments About the Rules</i>	7
<i>Location and Competition Information</i>	7
<i>Definitions</i>	7
<i>Schedule Summary &amp; Host Information</i>	8
<i>Competition Summary</i>	8
<i>On-Site Registration</i>	8
<b>General Rules of Competition</b>	<b>9</b>
<i>Number of Vehicles to Compete</i>	9
<i>Events of the Competition</i>	9
<i>Modification of Vehicles</i>	9
<i>Aerodynamic Devices</i>	9
<i>Vehicle Number and Logos</i>	9
<i>Fairness of Competition</i>	10
<i>Protests</i>	10
<i>Event Scoring</i>	10
<i>Energy Storage Devices</i>	10
<i>Report and Video Publication</i>	11
<i>Design Feedback</i>	11
<i>Readiness to Compete</i>	11
<b>Entry and Registration</b>	<b>12</b>
<i>Team Eligibility</i>	12
<i>Team Member Eligibility and Certification</i>	12
<i>Multiple Entries</i>	12
<i>Vehicle Design, Analysis, and Construction</i>	12
<i>Driver Requirement Exceptions</i>	12
<i>Late Vehicle Registration</i>	12
<i>Individual and Vehicle Registration fees</i>	13
<i>Refund of Registration Fees</i>	13
<i>Competition Information</i>	13
<i>On-Site Check-in</i>	13
<i>Late Check-in</i>	13
<b>Safety</b>	<b>14</b>
<i>General</i>	14
<i>Performance Safety Requirements</i>	14

<i>Minimum Braking System Requirement</i>	14
<i>Rollover Protection System</i>	14
<i>RPS Load Cases</i>	15
<i>RPS Attachment</i>	15
<i>Safety Harness</i>	16
<i>Custom Fabricated Harnesses</i>	16
<i>Testing Requirements for non-commercially produced harnesses</i>	17
<i>Testing Requirements for off application buckles</i>	17
<i>Exemptions</i>	17
<i>Vehicle Hazards</i>	17
<i>Clothing and Protective Equipment</i>	17
<i>Required Safety Test of Energy Storage Devices</i>	18
<i>Ride Logs</i>	18
<i>Safety Inspection and Demonstration</i>	18
<i>Modifications Affecting Safety</i>	19
<i>Disqualification of Unsafe Vehicles</i>	19
<b><i>Design Event</i></b>	<b>20</b>
<i>Objective</i>	20
<i>Description</i>	20
<i>Design Report</i>	20
<i>Design Report Organization</i>	21
<i>Design Report Content</i>	21
<i>ASME Report Cover Page &amp; Vehicle Description Form</i>	21
<i>Title Page</i>	21
<i>3-View Drawing of Vehicle</i>	22
<i>Abstract</i>	22
<i>Design</i>	22
<i>Analysis</i>	22
<i>Testing</i>	23
<i>Conclusions</i>	24
<i>References</i>	24
<i>Appendices</i>	24
<i>Prior Work</i>	24
<i>Design Report Submittal</i>	24
<i>Late Reports</i>	24
<i>Design Presentation</i>	25
<i>Objective</i>	25
<i>Description</i>	25
<i>Time Limit</i>	25

<i>Content &amp; Scoring</i>	25
<i>Design Presentation Content</i>	25
<i>Safety Video</i>	26
<i>Overview</i>	26
<i>Performance Safety Tests</i>	26
<i>Safety Analysis and Features</i>	26
<i>Video Submission</i>	26
<i>Static Judging</i>	26
<i>Design Scoring</i>	27
<i>Design Score Penalties</i>	27
<i>Overall Design Scoring</i>	27
<b><i>Speed Event (Sprint or Drag Race)</i></b>	<b>28</b>
<i>Sprint Race</i>	28
<i>Objective</i>	28
<i>Description</i>	28
<i>Sprint Course Description</i>	28
<i>Timing Area</i>	28
<i>Live Standings</i>	28
<i>Drivers' Meeting</i>	28
<i>Starting Order</i>	29
<i>Line Position Forfeiture</i>	29
<i>Start Assistance</i>	29
<i>Number of Attempts</i>	29
<i>Interruption and Termination</i>	29
<i>Scoring</i>	29
<i>Drag Race</i>	30
<i>Objective</i>	30
<i>Description</i>	30
<i>Duration and Timing</i>	30
<i>Drag Course Description</i>	30
<i>Timing Area</i>	30
<i>Live Standings</i>	31
<i>Drivers' Meeting</i>	31
<i>Race Description</i>	31
<i>Qualifying Race</i>	31
<i>Brackets and Seeding</i>	31
<i>Drag Race</i>	32
<i>Race Forfeiture</i>	32
<i>Start Assistance</i>	32

<i>Interruption and Termination</i>	32
<i>Scoring</i>	33
<i>Concurrent Event</i>	33
<i>Fouls and Penalties</i>	33
<b>Endurance Event</b>	<b>34</b>
<i>Objective</i>	34
<i>Description</i>	34
<i>Endurance Course</i>	34
<i>Start</i>	34
<i>Pits</i>	35
<i>Start Assistance</i>	35
<i>General Obstacles</i>	35
<i>Venue Specific Challenges</i>	36
<i>Lap Counting Process</i>	40
<i>Driver/Stoker Requirements</i>	40
<i>Judging Area</i>	40
<i>Drivers' Meeting</i>	40
<i>Course Practice</i>	41
<i>Signals</i>	41
<i>Disabled Vehicles</i>	41
<i>Fouls and Penalties</i>	42
<i>Interruptions</i>	42
<i>Termination</i>	42
<i>Scoring</i>	42
<b>General Fouls and Penalties</b>	<b>44</b>
<b>Overall Scoring</b>	<b>46</b>
<b>Announcement of Results and Awards</b>	<b>47</b>
<i>Announcement of Results</i>	47
<i>Presentation of Awards</i>	47
<i>Competition Awards</i>	47
<i>Other Awards</i>	47
<i>Review and Modification of Results</i>	47
<b>Clarification and Modification of Rules</b>	<b>48</b>
<i>Clarification and Modification of the Rules</i>	48
<i>Global Chief Judge and Head Judges</i>	48
<i>Questions and Comments About the Rules</i>	48
<b>Appendix 1 Design Event Judge's Score Sheet</b>	<b>49</b>

<b><i>Appendix 2: Protest Form</i></b>	<b>51</b>
<b><i>Appendix 3: Safety Exemption Request Form</i></b>	<b>53</b>
<b><i>Appendix 4: ASME Report Cover Page &amp; Vehicle Description Form</i></b>	<b>54</b>
<b><i>Appendix 5: Suggested Reference Material</i></b>	<b>55</b>

## I. General Information

### A) Objective

To provide an opportunity for engineering students to demonstrate application of sound engineering principles toward the development of practical, efficient, and sustainable human-powered vehicles.

### B) Superiority of Rules

These rules have been established by ASME's Human Powered Vehicle Challenge (HPVC) Committee. Should any conflict arise between these rules and those of the ASME, the ASME rules shall dominate. Should any conflict arise between these rules and other information regarding the ASME HPVC, whether generated by the ASME or any other organization, these rules shall dominate.

### C) Questions and Comments About the Rules

Questions about the rules must be posted on the HPVC Question Forum listed below (section 1.D).

### D) Location and Competition Information

Locations of all competitions can be found on the official HPVC website. Teams wishing to participate should consult the HPVC website, ASME HPVC Community on Facebook, and HPVC Questions Forum.

Official HPVC Website: <https://community.asme.org/hpvc/default.aspx>

Official Rules and Forms: <https://community.asme.org/hpvc/w/wiki/13013.competition-rules.aspx>

HPVC Facebook Community: <http://www.facebook.com/ASMEHPVC>

HPVC Question Forum: <https://groups.google.com/forum/#!forum/asmehpvc>

### E) Definitions

**Competition:** an individual HPVC hosted at a location around the world (e.g. HPVC West)

**Event:** an element of the competition (e.g. Speed Event)

**Team:** a group competing in the competition consisting of a vehicle and team members

**Vehicle:** a single entry in a competition

**Individual:** a single participant of a competition and likely a team member

**Driver:** any individual who is or will be riding in a vehicle during a competition

**Competitor:** an individual who is competing in a specific event at a competition (ie driver, presenter, team member)

**Registration:** the process to collect fees and record individual and vehicle information by ASME

**Check-in:** the process and act of reporting an individual's and/or vehicle's presence at a competition

*F) Schedule Summary & Host Information*

The ASME HPVC website shall specify all the important dates and contact information for the relevant competition.

The following is required for participation in the ASME Human Powered Vehicle Challenge. The required materials must be submitted as indicated in accordance with the schedule as noted. Please refer to the ASME HPVC competitions website for exact dates, submission links, and registration instructions.

<https://community.asme.org/hpvc/w/wiki/6688.competitions.aspx>

<b>Document</b>	<b>Method of Submission</b>	<b>Date Due</b>
Vehicle Registration	Every team must register online via E-Fest website	14 days before report deadline
Design Report	Electronic submission via competition website	45 days before competition
Individual Registration	Every team member must register online via E-Fest website	1st day of competition
Individual Ride Log	Every driver must submit online via competition website	1 week before competition
Performance Safety Video	Electronic submission via competition website	1 week before competition
Safety Exemption Request (Section XIV. Appendix 3)	Submit only if an exemption is requested and submit to Head Judge	1 week before competition
Protests (Section XIII. Appendix 2)	Submit to Head Judge only if required	In accordance with II.G

*G) Competition Summary*

Each competition shall include three events: a design event, a speed event, and an endurance event. Scores from each event are totaled to obtain the overall score to determine the winner.

*H) On-Site Check-in and Registration*

On-site check-in and registration begins on the first day (typically on Friday morning) of the competition. All teams and drivers must check-in (in person) before the end of the registration period to receive their vehicle numbers and wrist bands (required to be eligible as a driver).



## II. General Rules of Competition

### A) *Number of Vehicles to Compete*

There may be a cap on maximum number of teams at any competition. If so, it will be listed on the competition website at least 90 days before the competition. There is no requirement for a minimum number of vehicles. However, should the number of vehicles entered be more than one but less than four, the number of awards granted for overall placement in that event shall be one less than the number of competing vehicles.

### B) *Events of the Competition*

- Design Event: Teams are scored on their application of sound engineering principles and practices toward a vehicle design. This event includes a written report, a technical presentation, performance safety video, and static judging of their vehicle.
- Men's and Women's Speed Event: Teams are scored on the speed of their vehicles, either in a flying start 100 meter sprint or a head-to-head drag race from a standing start. The ASME HPVC Committee will announce which event will be held well in advance of the competition. Separate scores for men and women are recorded for this event.
- Endurance Event: Teams are scored on speed, practicality, performance and reliability of their vehicles in a road race format with urban transportation obstacles and challenges.

### C) *Modification of Vehicles*

Modifications to the vehicle are allowed between events, as long as safety is not compromised. Vehicles must retain their main frame and general drivetrain configuration. Any vehicle deemed to have undergone changes in excess of this allowance will be permitted to compete if it does not present a safety risk; however, any scores achieved will not be credited to the original entry.

### D) *Aerodynamic Devices*

Vehicles may include components, devices, or systems engineered specifically to reduce aerodynamic drag. Front fairings, tail sections, full fairings, and other such devices are encouraged. The effectiveness of aerodynamic devices must be substantiated in the design report in order to receive credit for the design scores regarding aerodynamics.

Make-shift devices which are unrepresentative of the design, are crudely crafted, and/or present a clear safety concern will be prohibited, and must be removed prior to racing unless previously granted a waiver by the Head Judge. Fairing configurations may be changed between events in accordance with Section II.C provided that all safety requirements, including the seat belt and Rollover Protection System (RPS) rules, are not compromised by the change of configuration.

### E) *Vehicle Number and Decals*

The Head Judge will assign each vehicle a number. The number "1" will be granted to the overall winner from the prior year's competition. All other numbers will be assigned. At his/her discretion, the Head Judge may consider requests for specific vehicle numbers, but number zero or numbers greater than double digit numbers will not be allowed. Requests can be made by sending an email to [hpvcasme@gmail.com](mailto:hpvcasme@gmail.com)

Decals – ASME will provide two adhesive decals to each team during the on-site check-in process. Each decal will display the assigned vehicle number as well as the HPVC logo. Each vehicle must provide sufficient space on either side for these decals. This space may include fairings, cargo containers, or surfaces especially designed for this purpose. The decals shall be no

larger than 35 cm wide x 30 cm high. If one or both of the decals are lost, obscured, or difficult to see from either side of the vehicle, the vehicle shall be removed from the competition until they are restored. If a vehicle number is obscured during the endurance race, any laps run without a visible number will not be counted.

School Name – All vehicles should display their school name or initials on each side of the vehicle in characters at least 10 cm high in a color that contrasts with the background.

F) *Fairness of Competition*

All participating teams will be assured an equal opportunity and a fair competition. Any participating team that, in the reasoned opinion of the judges, seeks to exert an unfair advantage over other competitors will be subject to a penalty in performance points or disqualification from the competition.

G) *Protests*

Protests must be announced to a member of the competition judges either at the time of the incident or within a 15 minute period following the announcement of results of the event. Following the announcement of the intent to protest, a written protest must be presented within 30 minutes unless otherwise allowed by the Head Judge. Oral protests will not be recognized. The Protest Form is available in the appendices.

Protests must be specific in nature and must include a factual account of the event being protested and the specific rules infraction, or the perceived error in the scoring of an event. Protests will be examined and resolved by the judges at their earliest convenience during the competition. Their decision will be final and without further appeal.

H) *Event Scoring*

Scoring for each event and the overall scores will be based on a points system. The team with the most points wins the event.

I) *Energy Storage Devices*

Vehicles may employ the use of energy storage devices for purposes of accelerating and improving performance of their vehicles, but by no means are they required. If energy storage is used energy must be stored after the race has begun with human power as the sole external source of energy. Prior to each race, each team must demonstrate that their storage device has zero propulsive energy stored.

During the safety inspection the team must be prepared to discuss the safety of the storage device, especially during a high-speed incident. Teams whose vehicle presents an unacceptable risk in the perception of the judges will not be allowed to utilize the energy storage device in the competition.

Stored energy used to power non-motive systems (does not impart momentum to the vehicle) is allowed and may be stored prior to the beginning of the race.

Combustion engines are excluded from the competition.

J) *Report and Video Publication*

After the completion of the annual competitions, all design reports and submitted videos will be published to a shared website.

If a team does not want their design report and/or video posted publicly, the team must submit a request, in writing, to the Head Judge no later than the submission deadline. The request must convincingly outline the grounds (such as active NDAs, or submission for intellectual property) for which the request is being made, and teams must be prepared to present an alternative submission omitting any specific sections in question. Requests will be granted or denied by the judges, and their decision will be final and without appeal.

K) *Design Feedback*

In an effort to help teams learn from their experience, the competition judges will be providing feedback on each team's performance in the Design event.

During the evaluation of the design reports and presentations, the judges will take note of specific areas where teams may be able to most improve their scores. Judges will be looking for things like areas that may be missing key details, where teams missed the mark with information provided or just generally in what areas the team can improve the most. Feedback provided will be constructive and actionable so that teams will walk away with a better understanding of the scores they received and how they can improve their skills further.

Feedback will be collected in a standard written format and delivered to the team captain after the conclusion of the competition.

Note: No action is required from teams to receive feedback outlined here, this section is simply included in the rules as informational.

L) *Readiness to Compete*

Teams must show up ready to compete and repair facilities will only be provided if the host offers. The host is not responsible for assistance with vehicle repairs. All vehicles must arrive at the competition ready to ride and pass safety inspection.

### III. Entry and Registration

#### A) *Team Eligibility*

Entry in the Human Powered Vehicle Challenge is open to teams from any college or university in the world.

#### B) *Team Member Eligibility and Certification*

All members of the respective school's team must be enrolled as full-time students in any program of study at that school. Any individual that is currently a full-time student, enrolled for the next upcoming semester/quarter, or has been enrolled for the previous semester/quarter, but graduated no earlier than six months prior to the competition date, is eligible to fully participate in the ASME HPVC. The faculty advisor and team captain must be from the engineering department of the college or university.

All the teams must complete a vehicle registration and individual registration for all team members. A registered participant can be the captain of only one team. All the drivers must submit a ride-log before the competition.

#### C) *Multiple Entries*

Multiple teams are allowed from a single university provided that they have different team captains and drivers. Each individual driver may only race in one vehicle for each racing event. In other words, **no driver should compete in multiple entries for any single racing event.**

#### D) *Vehicle Design, Analysis, and Construction*

The research, analysis, and design of all vehicles entered by a school must be performed solely by current eligible team members. All student team members shall be listed on the team's certified roster. Construction of the vehicle may include the assistance of outside vendors where the required capabilities exceed those available at the school.

#### E) *Driver Requirement Exceptions*

All racing events require that teams have at least one driver of each gender. Significant penalties are incurred for teams that do not meet this requirement, as described in the rules for each event. An exception to the eligibility rule may be granted to allow drivers to compete for a school other than that in which they are enrolled, as described below. No other exceptions will be allowed.

If a participating school's roster cannot support at least one complete crew (group of drivers) including each gender, that school may request the voluntary participation of one or more drivers from volunteers in attendance provided that the volunteer 1) meets all eligibility requirements from rule III.B and 2) will not participate in the same event for any other team. The requester must submit a written request for a waiver of the rules for this purpose to the Head Judge for approval prior to the start of the applicable event. Scores derived in this manner will be credited to the requester.

#### F) *Late Vehicle Registration*

At its sole discretion, ASME may consider late vehicle registration after the entry date.

*G) Individual and Vehicle Registration fees*

The registration fees for the competition may differ depending on the competition. The specific fees will be outlined on the competition and E-Fest websites.

*H) Refund of Registration Fees*

Online vehicle and individual registration is managed by the ASME E-Fests staff. Requests for refunds should be made directly to them via the contact information on the ASME E-Fests website.

*I) Competition Information*

The following information, or a URL for a website that contains this information, shall be provided to each team:

- A vehicle number
- List of deadlines
- On-site check-in location and time
- A map showing the location of the various events
- A schedule of events
- Course maps for the Speed and Endurance events

*J) On-Site Check-in*

All competitors must check-in on-site with ASME E-Fest and HPVC staff before participating in the competition. Check-in location and time shall be provided to teams on the event website.

During the on-site check-in process teams may:

- Receive identification for each driver (arm stamp, wrist bracelet, etc.)
- Receive two decals to display their assigned vehicle numbers
- Receive a final schedule, including times, locations, and other event information.

*K) Late Check-in*

Late check-in will only be possible if prior arrangements have been made with the Head Judge, at least one week in advance of the competition start date.

#### IV. Safety

##### A) *General*

The safety of participants, spectators, and the general public will override all other considerations during the competition. The judges will consider the safety features of the competition courses, as well as those of the competing vehicles, in permitting each event of the competition to begin or continue. Any event of the competition may be delayed, terminated prematurely, or canceled if the Head Judge, in consultation with ASME and the competition judges, determines that such action is necessary in the interest of safety.

##### B) *Performance Safety Requirements*

Each vehicle must demonstrate that it can come to a stop from a speed of 25 km/hr in a distance of 6.0 m (19.7 ft), can turn within an 8.0 m radius (26.2 ft), and demonstrate stability by traveling for 30 m (98.4 ft) in a straight line at a speed of 5 to 8 km/hr (fast paced walking speed).

##### C) *Minimum Braking System Requirement*

At a minimum each vehicle must have a braking system with properly designed brakes on the front most wheel of the vehicle. If multiple forward wheels are employed (such as in a tadpole trike or quad bicycle design) each wheel must have its own brake. Simply put, vehicles must at least have front brakes.

Even though teams may employ front brakes as outlined here teams are still responsible to conduct adequate testing to ensure that the vehicle can pass the stopping performance test outlined in the performance safety requirements.

##### D) *Rollover Protection System*

All vehicles must include a rollover protection system (RPS) that protects all drivers in the vehicle in the event of an accident. Functionally, the RPS must:

- Absorb sufficient energy in a severe accident to minimize risk of injury
- Prevent significant body contact with the ground in the event of a fall (vehicle moves from upright to resting on its side) or rollover (vehicle moves from upright to an inverted position)
- Provide adequate abrasion resistance to protect against sliding across the ground. This is particularly important around the driver's arms and legs. Adequate guarding must be included

The RPS must allow for a load path supporting the driver and retaining them from being ejected from the HPV in the event of a crash. This load path will be defined from the ground (impact point), to the outside of the vehicle body, through the structural RPS, through the safety harness, to the driver's body (center of gravity). A thorough RPS design includes the structural fortitude of not only the roll bar/frame, but also a rigidly mounted and structurally sound seat and properly affixed safety harness. In the RPS analysis teams must document the load path from driver to ground to receive full points.

In order to demonstrate the effectiveness of the RPS in protecting body contact from the ground teams may be required, during safety check, to lay their vehicle on its side as well as invert it fully with the largest driver inside. Once laying on its side and inverted the driver must not make contact with the ground and if safety is compromised vehicle modifications will be required or vehicle will not be allowed to race.

The RPS must fully protect the driver in a continuously hoop, a three point design **does not** meet this requirement. In order participate in the competition, all RPS structural components (including the continuous hoop) must be physically tested or analyzed to ensure safety while riding. In addition, the RPS shall meet the top and side load requirements described below.

### 1) RPS Load Cases

The RPS system shall be evaluated based on two specific load cases – a top load representing an accident involving an inverted vehicle and a side load representing a vehicle fallen on its side. **In all cases the applied load shall be reacted by constraints at the safety harness attachment points**; simulating the reaction force exerted by the driver in a crash.

- (a) Top Load: A load of 2670 N per driver/stoker shall be applied to the top of the roll bar(s), directed downward and aft (towards the rear of the vehicle) at an angle of 12° from the vertical, and the reactant force must be applied to the seat belt, seat, or roll bar attachment point and not the bottom of the roll bar (unless the bottom is the attachment point). Note that there may be one roll bar for the driver and another roll bar for the stoker which will result in each RPS having an applied load of 2670 N, or the driver and stoker can both be protected by a single roll bar which will result in the RPS having an applied load of 5340 N.

The roll bar is acceptable if 1) there is no indication of permanent deformation, fracture, or delamination on either the roll bar or the vehicle frame, 2) the maximum elastic deformation is less than 5.1 cm and shall not deform such that contact with the driver's helmet, head or body will occur.

- (b) Side Load: A load of 1330 N per driver/stoker shall be applied horizontally to the side of the roll bar at shoulder height, and the reactant force must be applied to the seat belt, seat, or roll bar attachment point and not the other side of the roll bar. Note that there may be one roll bar for the driver and another roll bar for the stoker which will result in each RPS having an applied load of 1330 N, or the driver and stoker can both be protected by a single roll bar which will result in the RPS having an applied load of 2670 N.

The roll bar is acceptable if 1) there is no indication of permanent deformation, fracture or delamination on either the roll bar or the vehicle frame, 2) the maximum elastic deformation is less than 3.8 cm and shall not deform such that contact with driver's helmet, head occurs.

### 2) RPS Attachment

The RPS must be structurally attached and braced to the vehicle frame or fairing and, with the vehicle in the upright position, must extend above the helmeted head(s) of the driver(s) such that no part of any driver will touch the ground in a rollover or fall over condition. The RPS may be incorporated into the fairing, providing that that part of the fairing is used in all events. Teams must demonstrate that the RPS meets both functional requirements and loading requirements. See Figure 1

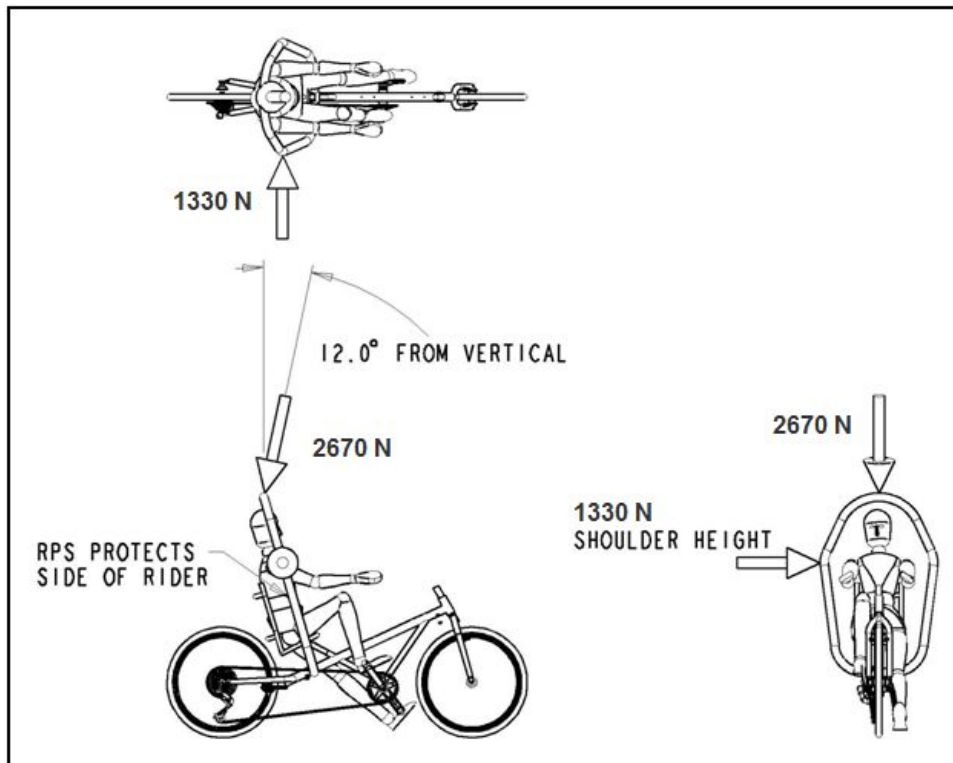

**Figure 1: Example of Proper RPS Design and Side and Top Load Case Applications (Note: Loads shown should not be applied concurrently in analysis and/or testing. Reaction loads should be applied at safety harness attachment points)**

E) *Safety Harness*

All drivers of all vehicles in all events must be secured to their vehicle by **safety harnesses with with lap and shoulder belts** (also known as 4 or 5 point safety harnesses) at all times that the vehicle is in motion. Lap belts or shoulder belts alone will not be sufficient and will require upgrading prior to racing. Commercially available harnesses designed for automotive, aviation or racing applications will generally be accepted without test data for the straps and buckles. Test data for attachment points may still be required at the time of the safety inspection.

Harnesses should be adjusted as firmly as possible, consistent with comfort, to provide the protection for which they have been designed. The safety harness must prevent any upward or forward motion of the driver's torso. Any slack in the harness must be adjusted by using the seat belt length adjuster. The safety harness must always be worn tight and fastened to prevent the driver from having free movement when the vehicle is in motion. Loose safety harness while riding the vehicle will be subjected to penalty for safety violation.

The safety harnesses must be attached to the RPS or a structural member in the RPS and may not be attached to the seat unless it is structurally integrated into the RPS.

1) Custom Fabricated Harnesses

If the harness is custom fabricated by the team or a commercial entity not in the business of producing harnesses or webbing products designed for use in life supporting application (i.e. climbing, racing, automotive), significant test data will be required, as defined below.



- Hand stitching of webbing is not acceptable under any situation. Machine stitching will be acceptable with supporting test data.
- Webbing connections secured with a properly tied water knot will be accepted without test data.
- The minimum acceptable width for harness webbing is 25mm.

## 2) Testing requirements for non-commercially produced harnesses

- Tensile test samples of a stitched joint must be prepared in an identical manner to the intended production method including: Base webbing material, thread, stitching pattern and quantity.
- Tensile tests performed on a minimum of 5 samples must show a 95% statistical confidence of an ultimate strength in excess of 3340 N.

## 3) Testing requirements for off application buckles

- Off application is defined as a buckle designed for anything other than a life supporting applications (automotive, aviation, climbing, etc.). Other buckles designed for life supporting applications will be accepted without testing documentation.
- Plastic buckles of any type are not permitted.
- Tensile tests performed on a minimum of 5 samples must show a 95% statistical confidence of an ultimate strength in excess of 3340 N.

### F) *Exemptions*

Any team may request an exemption from rule **Section IV.D and/or Section IV.E** using the Section XVII Appendix 5: HPVC Safety Exemption Request Form. The request must be based on the safety of the driver or general public, and must be submitted in writing to the Head Judge within deadline(Section I.E). The request must convincingly argue that safety is enhanced by omitting the safety harness and/or the RPS. Waivers will generally not be granted for fully faired vehicles, recumbent vehicles, or vehicles with three wheels. Requests for waivers will be granted or denied by the judging committee, and their decision will be final and without appeal. Without a waiver granted by the competition judges, teams without the RPS and/or safety harness will not be able to compete in any racing event.

### G) *Vehicle Hazards*

All surfaces of the vehicle—both on the exterior and in the interior in the region of the driver(s) and in the access area—must be free from sharp edges and protrusions, open tube ends, screws protruding more than three threads, and other hazards. All drivetrain components, steering components, and wheels must be fitted with appropriate guards if within reach of the driver and must be designed and constructed so that they will not injure the driver in the event of an accident.

### H) *Clothing and Protective Equipment*

All participants must wear fully enclosed shoes (entire foot is covered), appropriate clothing and properly fitting helmets with fastened straps that meet CPSC Safety Standard for bicycle helmets (16 CFR Part 1203) or equivalent while:

- Warming up or orienting themselves on any event course,
- Riding in all events and safety check, and
- Riding any competing vehicle or other human powered vehicle on or in close proximity to an event course.

Note that this requirement applies to all participants riding any HPV or bicycle, including personal vehicles. The helmets must be worn properly. Loosely worn helmets will be subjected to a safety violation penalty.

I) *Required Safety Test of Energy Storage Devices*

Vehicles that utilize energy storage devices shall specifically address the safety of the device or system in the design report and during the safety inspection. In particular, safety in the event of a high-speed accident shall be addressed. Teams whose vehicles present an unacceptable risk in the perception of the judges will not be allowed to utilize the energy storage device in the competition.

J) *Ride Logs*

All drivers and stokers will have had no less than 30 minutes of riding experience in their vehicle prior to the competition. Each team shall present a ride log through online form prior to the competition that clearly indicates the driver's name, date, duration in hours and minutes, and location for each ride or vehicle test. A failure to submit the ride log will result in the driver being not allowed to compete in any of the events.

K) *Safety Inspection and Demonstration*

A competition official shall oversee tests of each vehicle's ability to meet the braking, turning, and forward motion requirements. Each vehicle shall be visually inspected by the judges to ensure that no hazards exist that are likely to cause harm to the driver, passengers, competitors, or spectators. Potential hazards include but are not limited to defects or play in the steering system, sharp edges, protruding bolts, open tube ends, and pinch points. In addition, the vehicle must provide the driver with a forward facing field of view of at least 180° wide.

The rollover protection system must appear substantial and correctly installed. The tallest driver on the team must sit in the vehicle with the safety harness locked and demonstrate the roll bar assembly extends beyond the driver's helmeted head and shoulders. It would be required to flip your vehicle completely during the safety inspection. If the team plans to use the fairing during the racing events then the safety inspection must be completed with the fairing attached with the vehicle

The safety check will take place during the scheduled safety inspection time block. No vehicle will be allowed to participate in any race unless it has successfully completed the safety check. It is expected that teams evaluate the safety of their vehicles before they arrive for the safety inspection. This includes the mitigation of all safety hazards (Section III.G) as well as performance safety requirements (Section IV.B). All teams will be granted at least one attempt at a successful safety evaluation, but any team that fails the safety inspection may make a request to the safety judge for a re-inspection at a later time. Such re-inspection will be granted at the sole discretion of the safety judge based on available time. If the re-inspection occurs after the designated inspection time block for that team, the team may be assessed a design score penalty up to 10%. Note: if time does not permit a team to complete their safety inspection they will not be allowed to race until a re-inspection time has been scheduled and the inspection has been completed successfully.

L) *Modifications Affecting Safety*

Modifications to vehicles between events is allowed but it must not compromise the safety of the vehicle. If the competition officials determine that any modification has reduced the safety of the design to an unacceptable level, the vehicle will be disqualified from the affected event of the competition.

M) *Disqualification of Unsafe Vehicles*

The competition officials reserve the right to remove from the competition, any vehicle that is judged to be unsafe by any metric. Drivers must always be in control of their vehicles. Loss of control of a HPV such that it poses an immediate safety risk to the driver, spectators, or any other person(s) may constitute immediate suspension barring said vehicle or specific drivers from further racing of the HPV in that event and subsequent events. This determination will be made by the Head Judge, in consultation with the competition judges, and ASME staff, and will be final. This includes consideration of a vehicle's perceived performance under prevailing weather conditions.

Petitions for a disqualified vehicle or driver to be reinstated into the competition can be made on the grounds that safety concerns have been corrected, or on a driver-by-driver qualification that will be conducted to prove that he or she can handle the vehicle to the satisfaction of the competition judges. The considerations to reinstate removed vehicles or drivers will be made by the judges if sufficient time is available and will not be made if it impedes the function of the judging staff during an ongoing event. There is no guarantee that a disqualified vehicle or driver will be reinstated and all decisions by the judges will be final.

## V. Design Event

### A) Objective

To demonstrate the effective application of established principles and practices of design engineering to the development of the team's vehicle.

### B) Description

The Design Event includes four parts:

1. Design report submitted in advance of the competition
2. Safety video submitted in advance of the competition (See IV.L Performance Safety Video)
3. Design presentation to the competition judges during static inspection (See V.I Presentations)
4. Safety and static inspection by competition judges

### C) Design Report

The report should concisely describe the vehicle design and document the design, analysis, and testing processes and results. The report should have the character of a professional engineering report and should be organized as described in Section V.D.

Reports should emphasize clarity both in presentation and in the statement of results and conclusions. Photographs and drawings are encouraged where beneficial in documenting unique features of the design.

Design reports shall use 12 point Calibri font, single line spacing within paragraphs and double line spacing between paragraphs. Major headers shall be 14 point Calibri Bold, left justified. Margins shall be 1 inch top, bottom, left, and right. All figures and tables shall include a caption in 10 point Calibri italic font. Avoid watermarks and graphics that obscure text legibility.

Report writers should note that bulk is not a desirable feature; therefore, reports have a **26 page maximum limit**. (The limit includes the following sections: Design, Analysis, Testing and Conclusion. Required ASME Report Cover Page & Vehicle Description, the 3-view drawing, the abstract, and references will not be included in the page count. Penalties will be levied for exceeding the page limit (See Section V. M). Additionally, judges will not consider any page beyond the 26th.

A copy of the judges score sheet is included in Appendix 2 of these rules. Teams are strongly encouraged to carefully read the score sheet prior to writing the design report.

Teams are expected to comply with ASME's Code of Ethics in the creation of their reports.

D) *Design Report Organization*

The design report shall be organized as follows:

- |       |   |  |
|-------|---|--|
| I.    | ASME Report Cover Page & Vehicle Description Form   | No page number   |
| II.   | Title Page  | No page number   |
| III.  | 3-View Drawing of Vehicle                           | No page number   |
| IV.   | Abstract  | Page i   |
| V.    | Table of Contents                                   | Page ii  |
| VI.   | Design  | <b>Page 1, First page that counts towards limit.</b>                     |
|       | a. Objective  |  |
|       | b. Background                                       |  |
|       | c. Prior Work                                       |  |
|       | d. Organizational Timeline                          |  |
|       | e. Design Specifications                            |  |
|       | f. Concept Development and Selection Methods        |  |
| VII.  | Analysis  |  |
|       | a. RPS Analyses                                     |  |
|       | b. Structural Analyses                              |  |
|       | c. Aerodynamic Analyses                             |  |
|       | d. Cost Analyses                                    |  |
|       | e. Other Analyses                                   |  |
| VIII. | Testing   |  |
|       | a. RPS Testing                                      |  |
|       | b. Developmental Testing                            |  |
|       | c. Performance Testing                              |  |
| IX.   | Conclusion  |  |
|       | a. Comparison – Design goals, analysis, and testing |  |
|       | b. Evaluation                                       |  |
|       | c. Recommendations                                  | <b>Last numbered page, Last page that counts towards the page limit.</b> |
| X.    | References  |  |
| XI.   | Appendices  |  |

E) *Design Report Content*

Content of each section should be in accordance with the design report score sheet (see Appendix 2).

a. ASME Report Cover Page & Vehicle Description Form

The first page should be the completed ASME Report Cover Page & Vehicle Description Form, available in the appendix of these rules

b. Title Page

The title page should include the report title, vehicle number (assigned by ASME), names of team members including contact information for two designated team members, and the name and contact information of faculty advisor.

c. 3-View Drawing of Vehicle

Include a drawing of the complete vehicle with at least front, top, and side projections. Key dimensions such as wheelbase, track, overall length and overall width should be included. Drawings to follow ASME Y14.5 and related standards such as ASME Y14.24 and ASME Y14.3

d. Abstract

The abstract should give a clear summary of the objectives, scope, and results of the vehicle design. It should be limited to no more than 300 words.

e. Design

The Design section should include an overall description of the vehicle with appropriate background information, design objectives, design criteria, and design alternatives that were considered. It should clearly demonstrate that established design methodologies, including structured design methods and engineering principles, were effectively used during the vehicle design process. Sub-sections include:

**Objectives:** Clearly state the objectives and design mission of the vehicle

**Background:** Include supporting research and review of prior art. Provide background information to justify your objectives, mission, design approaches, and design concepts. Background research should include specific information found/used to aid in design and development of the HPVC, but should not include your team's general competition history. Appropriate background research can include information found on HPV development, aerodynamics, HPV standards (such as ISO or Federal), competitive vehicles, etc. Cite references as appropriate.

**Prior Work:** Clearly document any design, fabrication, or testing that was not completed in the current academic year. If teams reuse work from previous years and it is not listed here teams will be assessed a penalty for reusing content.

**Organizational Timeline:** Include an organizational timeline or Gantt chart showing project scheduling and completion

**Design Specifications:** Provide the design specifications for the vehicle. Tables and bullets may be used. Also provide rationale or justification for the specifications as appropriate. Document methods (such as QFD) used to develop the specifications.

**Concept Development and Selection: Methods** Document the use of established concept development and selection tools such as the Pugh's Concept Selection Technique, etc.

**Description:** Describe the final vehicle design, making generous use of drawings and figures. Describe how the vehicle can be practically used, what environmental conditions (weather, etc.) were addressed and how components and systems were selected or designed to meet the stated objectives.

f. Analysis

The analysis section summarizes the engineering evaluation of the vehicle's performance and structural viability as related to the design criteria outlined in the description. **For each analysis**

**documented, the objective, modeling method & assumptions, results, and conclusions should be clearly indicated.** Conclusions should describe how the results were used to improve the vehicle, i.e. what changes were made as a result of the analysis.

Each sub-section should include a table summarizing all analyses completed in that section. The summary should include objectives, methods, and results. In addition, provide selected examples of specific analyses in sufficient depth to allow judges to evaluate the technical correctness of the analysis. The analysis section should include the following subsections.

**RPS Analysis:** Document the structural analysis of the rollover and side protection system. This section must convincingly demonstrate that the RPS is fully compliant with Section III.D of these rules in order to obtain full points.

**Structural Analysis:** Document structural analyses conducted on the frame or mechanical components. Specify objectives, load cases, methods, and results. FEA is an appropriate tool, but not the only tool, used for structural analyses.

**Aerodynamic Analysis:** Document aerodynamic analyses, including drag estimates, conducted on fairings, aerodynamic devices, or other components. CFD is an appropriate tool for aerodynamic analyses.

**Cost Analysis:** Provide a tabulated cost analysis of the HPV. The cost analysis should include capital investment, tooling, parts and materials, and 3<sup>rd</sup> party labor costs, but not student labor costs.

**Other Analysis:** Document other analyses conducted during the design process, including power/speed modeling, vehicle handling, stability, steering, suspension kinematics & dynamics, optimizations, etc.

g. Testing

The testing section documents physical tests and/or experiments conducted to develop or verify the design. **For each test, the objectives, methods, results, statistical analysis of data, conclusions, design modifications, and comparisons to product design specifications should be clearly described to acquire full points.** Test results should be compared with design specifications and analytical predictions and should document design changes/validations driven by said results. Sufficient examples should be included to demonstrate the extent to which physical testing was used during the design process. This section should include the following sub-section:

**Developmental Testing:** Document physical testing conducted to develop or optimize the vehicle design. This testing is usually done early in the design phase to aid in the design process. Include objective, methods, results, and conclusions. Examples of developmental testing include, but are not limited to testing weld quality, composite materials, RPS mock up, and prototype sub systems.

**RPS and Performance:** Testing results will be presented with safety information at the live presentation during the static judging and **not in the design report.**

#### h. Conclusions

Demonstrate that the design team completed a substantive evaluation of the vehicle design. This section should include the following subsections:

**Comparison:** Use a table to compare the vehicle design specifications with analytical performance predictions and experimental results. Were design objectives met?

**Evaluation:** Describe how the final vehicle was evaluated with respect to the objectives and design specifications.

**Recommendations:** Document any recommendations for future work on the vehicle, including but not limited to modifications and improvements.

#### i. References

Citations must be provided for all non-original content. Citations should be formatted in the IEEE Citation Style or similar scientific citation style.

#### j. Appendices

Appendices could contain supplementary material that is not an essential part of the report itself but it would be helpful in providing a more comprehensive understanding of your work. It could also contain information that is too cumbersome to be included in the report. This section of the report would not be scored

#### F) *Prior Work*

**Design credit will only be given for work (design, analysis or testing) done during the current academic year.** The report should clearly indicate if work consists of improvements to a previous design. To be considered a new design, the vehicle must be substantially different from previous or additional entries (in the event a school is submitting multiple entries into a single competition) by that team or school. It is acceptable to advance and refine the design of an existing vehicle, but the new developments must be clearly differentiated from prior work.

Scoring is based solely on the current year's work and design points will not be awarded for design work done in previous academic years. It is acceptable to use off the shelf (stock) components and/or you can reuse components from previous year's vehicles, but will not receive any design points.

Unoriginal content, including content generated from other teams or previous years and not cited, may be assessed a penalty for plagiarism.

#### G) *Design Report Submittal*

The design report must be submitted electronically as a PDF via a link on the competition website. See this website for the submission deadline.

#### H) *Late Reports*

Design reports will be accepted up to a week before the competition registration date, and subject to a 2.5% penalty per day the report is late. Teams that do not submit reports within 40 days after the Report Date will not be eligible for participation in the design event.



l) *Design Presentation*

a. Objective

The design presentation gives teams an opportunity to provide RPS & performance testing results and any updates following the design report.

b. Description

**During the design presentation teams are to present their RPS & performance testing results, safety analysis, and any design updates since the submission of the design report.** The presentation will take place during the static judging of the vehicle and should be accompanied by supporting material and visuals of testing results (See V.I.g). All the teams will come to the presentation area with their vehicle for the design presentation. Other teams are encouraged to watch as many presentations as they wish.

c. Time Limit

Design presentations will have a maximum time limit of 6 minutes followed by a maximum of 3 minutes of questions from the judges.

d. Content & Scoring

Presentations will be scored by the same judges who scored the submitted design reports. Any additional information which is typically included in a technical presentation, such as the general design of the vehicle must be omitted. **Only information regarding the testing of the vehicle will be scored. Content that is already included in the design report need not be presented at the time of presentation.**

Note: Scores for all other sections of the design report will **not** be updated during the presentation so it will benefit teams to focus specifically on testing

e. Design Presentation Content

(a) Testing

(i) RPS Testing

**Physical testing** of the RPS system should be documented and presented, including test setup, results and conclusions. Teams must treat the entire system from the driver to the ground as the RPS to achieve full points; including the seat, safety harness, attachment hardware and roll bar.

(ii) Performance Testing

Document physical testing done to verify vehicle performance. This testing must be conducted on the final version of the HPV or a prototype with similar properties of the system being tested. Document and present your objectives, methods, results and conclusions. Examples of performance testing include, but are not limited to, testing final vehicle performance capabilities, final frame geometry on prototype frame and aerodynamic testing on finished fairing.

(b) Supporting Material and Visuals Supporting material is encouraged; acceptable media includes posters, photographs, charts and other visuals. Live videos, photographs, data, and other digital visual media will be allowed, but teams are required to bring their own devices to display the information and electrical power may not be provided. Test data

should be tabulated in the supporting material clearly outlining the results and conclusions of the test.

J) *Safety Video*

a. Overview

One week before the competition, teams will submit a short video (maximum 2 minutes) showing their HPVs completing the performance safety requirement tests (Section IV.B) and their safety analysis and features (Section V.J.c)

b. Performance Safety Tests

The portion of the video featuring the performance safety tests can be very brief as it must only show the vehicle completing the tests, or if the tests cannot be completed successfully, teams must briefly explain how they will modify their vehicles to pass by the date of on site safety inspection. To conduct the tests a crude test set up and a visual estimate for vehicle speed will be acceptable.

c. Safety Analysis and Features

Teams are to conduct an analysis of potential hazards and how the team addressed safety of the 1) vehicle occupants, 2) bystanders and 3) vehicle builders during the construction of the vehicle (i.e. shop safety).

Features, components and systems designed to mitigate hazards should be described. Of particular interest is how established engineering principles were used to design safety systems. Teams must also address how their design protects the driver's head and appendages such that they do not contact the ground in the event of a crash where the vehicle falls over or inverts.

Teams are required to have at least one additional safety feature of their choosing which improves the safety of their specific vehicle design/configuration. The need, quality and perceived performance of the execution of this safety feature will be evaluated to determine points awarded. Standard safety features like helmets, seat belts and a RPS system do not qualify as an additional safety feature.

d. Video Submission

The safety video must be submitted electronically via a link on the competition website. Video files must be less than 500MB and in .mp4 format. See this website for the submission deadline.

K) *Static Judging*

During the design presentation and prior to the start of the safety inspection vehicles will be statically inspected. Vehicles will be visually inspected based upon the following items:

- Physical characteristics
- Design features
- Safety features
- Consistency with report
- Safety
  - At the time of safety inspection teams must have a functioning bell/horn, headlight, taillight, side reflectors and rearview mirror(s) in order to achieve points for safety accessories.
- Aesthetics

L) *Design Scoring*

Design scoring is based on the extent to which established engineering design principles were applied in the design process and the effectiveness of the design practices used. Scores will also reflect the effectiveness of the report, presentation and safety video in communicating the design process and solution. Design teams must address each of the specified topics in order to receive a score for that topic. Design scoring for all vehicles shall be as shown below:

<b>Subject Area</b>	<b>Maximum Points</b>
General	5
Design	15
Analysis	25
Testing	25
Safety	20
Aesthetics	10
<b>Total</b>	<b>100</b>

M) *Design Score Penalties*

In addition to those previously described, penalties may be imposed by the competition judges for failures to comply with the rules of the Design Event. Penalties will be assessed according to the following table in cases where an unfair advantage might have been gained or the Judges' ability to evaluate a design has been compromised.

<b>Rules Infraction</b>	<b>Maximum Penalty</b>
Report content largely non-original	Event Disqualification
Late report submittal	2.5% per day (Maximum of 100%)
Late for Static Judging or Safety Check	10%
Late submittal of safety video	0.5% per day (Maximum of 12.5%)
Safety video over time limit	5%
Over Page Limit ("non-participant" at 26 pgs over)	3% Per Page
Report does not conform to required outline	10%
ASME Report Cover Page & Vehicle Description	5%
Form missing from 1 <sup>st</sup> page or incomplete	1 point per page

N) *Overall Design Scoring*

The judges will compile the design scores including any penalties on a total points basis. The event score is given by

$$\text{Points} = \left( \frac{\text{Team Design Score}}{\text{Maximum Possible Design Score}} \right) \times \text{Maximum Event Points}$$

Where the Maximum Possible Design Score is the maximum points possible according to the Judge's Score Sheet, and the Maximum Event Points are given in Section IX.

## VI. Speed Event (Sprint or Drag Race)

The Speed Event will be either a sprint or a drag race format. The type of race will be determined and announced well in advance of the competition at the discretion of the competition judges and host. Separate speed events are held for men and women.

Please note, during the speed event **no outside assistance may be given to the driver(s) of any HPV.**

### A) *Sprint Race*

#### a. Objective

To provide teams the opportunity to demonstrate the top speed of their vehicles.

#### b. Description

The Sprint Event is an individual, timed event with a flying start to achieve top speed on a closed course. Each team shall include multiple drivers with separate scoring categories for both genders. The male and female sprint races shall be run concurrently.

#### c. Sprint Course Description

The course will consist of a straight, smooth, and level (less than 1% slope over entire course) paved surface. The timed portion of the course shall be 100 meters in length, preceded by a 400 to 600 meter "run-up" section and followed by a "run-down" section at least 200 meters in length. Where possible, the length of the "run-up" will be maximized.

The beginning of the run-up shall be marked by a starting line. All vehicles in line for a run shall remain in a marked staging area until directed by the start line official to move to the starting line. The course will include a separate route for returning vehicles from the "run down" end of the course to the starting area.

Hay bales or equivalent cushioning material will be used to protect vehicles and drivers from collision with any fixed obstacles located adjacent to the course. Such cushioning shall reflect proper safety design with due consideration to the estimated speed of passing vehicles and their direction along the course.

The course shall be clearly marked to indicate the start, time trap area, and finish.

#### d. Timing Area

The timing and scoring area, located at the end of the speed trap, will be off limits to spectators and all others except the competition officials and the event timing staff.

#### e. Live Standings

When possible vehicle speeds and standings shall be posted online so teams can monitor their progress.

#### f. Drivers' Meeting

All drivers who will participate in the Sprint Event must attend the mandatory Drivers' Meeting at approximately 45 minutes prior to the scheduled start of the race. The meeting will clarify operating procedures and signals and will identify course features, hazards, and landmarks.

By the time of the meeting all team equipment, vehicles and other required items should be in place and clear of the track. Any team that is not represented at this meeting will normally not be permitted to participate in the event; in cases of unavoidable absence, the team may file an appeal with the competition judges, whose decision regarding participation will be final.

g. Starting Order

The first round of sprint attempts will be assigned at random. Subsequent starts will be on a "first ready, first started" basis. Place holding in line is prohibited: a team is not considered ready unless both driver and vehicle are present and prepared to race. Teams will be notified of their staging order prior to the start.

h. Line Position Forfeiture

Each successive vehicle will have 15 seconds to begin a sprint attempt after the start line official has determined that the course is ready and safe for the event to proceed. If a vehicle is not ready within the 15-second period, the vehicle must stand aside for others that are ready to proceed. In extreme cases, the vehicle will forfeit the run and must re-enter at the end of the line.

i. Start Assistance

Assistance is not permitted. The driver must be completely self-sufficient from the beginning of the run until the vehicle crosses the finish line. As always, assistance is permitted in the event of an emergency, but once assistance is given the run is forfeit.

j. Number of Attempts

During the Sprint Event each vehicle will be allowed to make as many runs as time and conditions permit and all vehicles will be provided an equal opportunity to compete.

Although all competitors will have an equal opportunity to compete, there will be no assurance of an equal number of runs for all vehicles. Teams may take advantage of every opportunity to maximize their number of runs, or selectively pass opportunities.

Teams will be notified of race time remaining at 30 minutes, 15 minutes, and 5 minutes until the end of the race time. No team may make a run after the official end of race time.

k. Interruption and Termination

The Sprint Event will normally run continuously. However, circumstances such as equipment failures, an emergency or hazardous weather or wind conditions may require a delay or premature termination of the event. Delays or terminations will be determined by the Head Judge with the help of the competition judges and Director.

l. Scoring

The Sprint Event is scored separately for each gender. Thus each vehicle will have two sprint scores: one for male drivers and one for female drivers.

The point score for each vehicle is based on the winning time for the event, that is, the fastest time of any vehicle in the event. Points are awarded based on the following formula:

$$\text{Points} = \frac{t_{\text{Winner}}}{t} \times (\text{Maximum Event Points})$$

Where  $t_{\text{Winner}}$  is the time of the winning vehicle,  $t$  is the fastest time of the event for a particular vehicle, and the Maximum Event Points is the point value for the event, specified in Section IX.

*B) Drag Race*

a. Objective

To provide teams the opportunity to demonstrate the speed and reliability of their vehicles in a tournament format.

b. Description

The Drag Event is a head-to-head, tournament style race where two vehicles compete at a time from a standing start to be the first to cross the finish line.

c. Duration and Timing

The Drag Event ends when both the Men's and Women's events are complete and champions have been determined.

Every effort will be made to run the event as quickly as possible. This includes starting sequential heats as soon as the course is clear and lining up upcoming competing pairs of teams as early as possible. An exception will be made for teams which need to race back to back during the quarterfinals or semifinals. If a team needs to race back to back a 5 minute maximum rest period will be granted between the end of the previous race and the beginning of the following heat.

d. Drag Course Description

The drag race course shall consist of a paved and near level course of at least 200m and typically between 300 to 450 meters (984.3 to 1476.4 ft) in length. The course shall be at least six (6) meters (19.7 ft) wide at all locations. The surface shall be smooth and free of potholes, cracks, and debris. Curves are permitted on the course, which may be a closed loop (although a closed loop is not required).

The course immediately following the start and immediately preceding the finish line shall be straight, unless separate and equal length lanes are provided for each vehicle. If the course is not a closed loop there shall be a return path to the staging area.

The course may either be one shared course for both teams or a mirrored "rally track" style course where teams will turn in opposite mirrored directions. A head to head finish will still be prioritized with this configuration, but teams may diverge during the race with each team limited to their individual path. Each path will be as close to an exact mirror as possible with the layout, number of turns, turn radius, etc. being exactly the same. Where possible number of cones, signage, and other details will also be mirrored exactly.

e. Timing Area

The timing and scoring area shall be off limits to competitors, spectators, and all others except competition officials and the event timing staff.

f. Live Standings

If the race venue can support it, race results shall be posted online. Results should be updated after each individual race, and should indicate the winners' and losers' brackets and race times.

g. Drivers' Meeting

All drivers who will participate in the Drag Race Event must attend the mandatory drivers' meeting for that event. The drivers' meeting shall take place approximately 45 minutes prior to the scheduled start of the race. The meeting will clarify operating procedures and signals and will identify course features, hazards, and landmarks.

Any team that is not represented at this meeting will normally not be permitted to participate in the event; in cases of unavoidable absence, the team may file an appeal with the competition judges, whose decision regarding participation will be final.

h. Race Description

The Drag Race Event allows two teams at a time to race each other side by side from stationary at a starting line to a predetermined finish line.

The Drag Race Event is gender specific. Each driver shall compete against drivers of the same gender. Separate scores shall be kept for male and female drivers.

The drag race consists of two phases: qualifying and a double-elimination tournament drag race. All vehicles shall compete in the qualifying race. The vehicles with the fastest qualifying times shall compete in the drag tournament.

i. Qualifying Race

The event shall begin with the female driver qualifying race. After all female drivers have completed the qualifying race, the male qualifying race shall commence. In both male and female races, vehicles shall start in the order of vehicle number.

The maximum number of vehicles racing in each heat shall be at the discretion of the Head Judge, and will depend on the nature of the course and the available timing equipment (typically two). Each vehicle shall be timed separately. Qualifying race place is based on finish times.

**There may not be a qualifying race if there are less than 16 participating teams for the event.**

j. Brackets and Seeding

The top 16 vehicles from the qualifying race will advance to the elimination rounds in each gender. If there are less than 16 vehicles, then the tournament shall consist of 8 vehicles. If the venue and time window allow more than 16 vehicles may be able to compete in the tournament, and the exact number of teams will be announced during the drivers' meeting.

After the first round of eliminations, the event is split into two brackets: the winner's bracket and the loser's bracket. At the end of each round, the losers in the winner's bracket move into the loser's bracket. The losers of the loser's bracket are eliminated from the competition. The championship race determines the winner of the event. In the event that neither championship contestant has two losses after the round, an extra race will determine the winner.

Seeding shall be based on qualifying time. That is, the first race shall take place between the vehicles with the first and last qualifying times, the second race between the second and next to last qualifying places, and so on.

Tournament seeding and sequencing may be modified by the Head Judge to account for event-specific circumstances.

k. Drag Race

All races in the drag tournament shall be between two vehicles. The preferred racing lane will be given to the vehicle with the better seed position (faster qualifying time).

Vehicles will be instructed at the starting line of the race by a flag person. When both competitors indicate they are ready the flag person will start the race by waving the flag. No verbal command is required therefore the drivers must be able to clearly see the flag person. If a verbal command is given, it has no bearing on the race start. Only the waving of the flag should start the race. There will be a finish line judge (if not a closed loop) who will determine the winner of the race.

If a competitor moves before the flag is waved, the start line flag judge will call a false start. Teams will be allowed one (1) false start per gender, which will result in a verbal & visual warning, and a rerun of the same heat. Subsequent false starts will result in disqualification for the rest of that gender's tournament.

Following the completion of the race competitors must return to the staging area for succeeding elimination rounds. Once there teams will be instructed by the staging area coordinator.

Event and race sequencing will be determined by the Head Judge and announced at the drivers' meeting.

Disabled vehicles at the start or during the race will have no more than 20 seconds to make repairs or they will forfeit the race. Disabled vehicles must clear the course as rapidly as possible.

l. Race Forfeiture

Vehicles must be in line and ready to start in turn. If a vehicle is not ready to start at their turn, they forfeit the race and either move to the loser's bracket or are eliminated from the race. If a vehicle is unable to start within 20 seconds of the start signal it must forfeit the race. Forfeiture in the qualifying race makes the vehicle ineligible to compete in the drag tournament.

m. Start Assistance

Assistance is not permitted. The driver must be completely self-sufficient from the beginning of the heat until the vehicle crosses the finish line. As always, assistance is permitted in the event of an emergency, but once assistance is given the run is forfeit.

n. Interruption and Termination

The Drag Race Event will normally run continuously. However, circumstances such as equipment failures, an emergency, hazardous weather, or wind conditions may require a delay. Delays or terminations will be determined by the Head Judge with the help of the competition judges and



the competition Director. The Drag Race Event will end with the completion of the championship rounds for both genders.

o. Scoring

Scores for teams eliminated in the tournament shall be determined by the round in which the vehicle was eliminated. The place order for all remaining vehicles shall be determined by qualifying speed. Separate scores shall be maintained for each gender.

Scoring for teams that qualify in the tournament depends on the round in which they are eliminated from the tournament. See the table below for the example score breakdown for the tournament.

**Table 1: Drag Tournament Scoring for 16 Teams**

	Elimination Match							
Eliminated in Round:	Champion						20	12
		31			26	24	19	11
		30	29	28	25	23	18	10
Place	1	2	3	4	5	7	9	13
Points	12.5	11.6	10.8	9.9	9.1	8.2	7.4	6.5

Teams that do not qualify for the tournament will be scored based on time obtained in the qualifying round, in accordance with the following formulas:

$$\text{Points} = \frac{t_{\text{Fastest Non-Qualifying Time}}}{t} \times (6.0 \text{ Points})$$

*C) Concurrent Event*

During the Speed event, non-qualified teams may have the opportunity to participate in an alternative event. This event will also be briefly open to qualified teams after the Speed event is completed. The alternate event could include bonus points, and will be announced 90 days before the event start date.

*D) Fouls and Penalties*

Fouls and penalties for the speed event are described in the general fouls and penalties Section VIII

## VII. Endurance Event

### A) Objective

To provide teams the ability to demonstrate the functionality, agility, utility and durability of their vehicles.

### B) Description

The Endurance Event is a 2.5 hour, timed relay race with multiple laps around a closed course. Each team shall include multiple drivers and **both genders**.

### C) Endurance Course

The Endurance Event shall take place on a closed-loop course at least 1.5 kilometers in length.

- The course shall be continuously paved with occasional patches of rough pavement or gravel typical of a public roadway.
- The course shall include turns in both directions and straight sections designed to demonstrate the advantage of the vehicles' aerodynamic features.
- Up and down grades shall be included if possible, with maximum grades on the course to not exceed 5 % uphill or 7% downhill. The maximum vertical distance climbed in one lap shall not exceed 30 meters.
- The course shall include a paved section with no obstacles that is at least 1.0 kilometers long.
- Individual laps should be approximately two (2) kilometers in length, again to the extent that the event site permits; in no case, however, may the lap length be less than 1.5 kilometers.

### D) Start

The start of the race will be an unassisted LeMans style start

- Start Area* The start area shall accommodate a LeMans style start that includes a broad, straight section immediately preceding the start line. This area shall be wide enough to ensure a safe start. The start area will include a designated driver start area at least ten meters away from the vehicles parked in preparation for the start.
- Start Process* Start of the Endurance Event shall begin with all vehicles parked diagonally on one or both sides of the race course. Drivers will be positioned at least ten meters from their vehicle with a parcel of items positioned in front of the driver or adjacent to the vehicle. At the start signal, all drivers shall pick up the parcel, run to their vehicles, enter and buckle in, and then take off.
- Cargo* Start will include the pick-up and stowage of a parcel that must be carried until the first stop.
- Starting Order* Vehicles shall start each endurance race in the order of finish for the women's sprint or women's drag race. **Vehicles without a women's sprint or drag race score shall be placed at the end of the starting line-up in order of vehicle number.**
- Starting Driver* The starting driver may be of either gender and is subject to the minimum, maximum, and single ride limits (See VIII). In other words, teams may start the race with their fastest driver regardless of gender.
- Mechanical Malfunctions at Start* Any vehicle that requires mechanical assistance at the time of the start must forfeit its starting position and safely exit to the side of the course; it may rejoin the event at the rear of the field of competitors when ready. Repair work

that interferes with the safe and orderly start of an event may result in a penalty against the responsible team.

(g) *Caution Drivers* shall use caution during the start to avoid accidents.

*E) Pits*

The course layout must include pit work areas, including safe entry and exit; room for the starting line-up; and a straight run of at least 100 meters between the starting line and the first turn.

- Pit Location The pit area shall be located in an area adjacent to the course and shall begin not less than 30 meters and not more than 50 meters after the finish line. The pit area shall be located after, but in relatively close proximity to the start line.
- Pit Crews Due to space limitations, no more than eight crew members (excluding drivers) will be allowed in the pit area for each team. Crew members may not be in another team's pit area without permission.
- Pit Stalls Prior to the drivers' meeting, teams shall locate their pit stall. All equipment must be placed in the selected pit area prior to the drivers' meeting. During the race, all work in the pit area must take place within the selected pit stall and not in the pit lane. A typical pit stall is 2.6m x 4.9m in dimensions, but may vary as venues allow. (Failure to observe this rule will result in black flag penalties as described in VII Q.)
- Right of Way in the Pit Area Competing vehicles have the right of way on the course and in the pit areas at all times during an event. Vehicles entering the pit area from the course shall have the right-of way over those returning from the pits to the course. Interfering with a competing vehicle in any way may result in a penalty assessment against the responsible team.

*F) Start Assistance*

No assistance shall be provided to any driver except in the pit area (except in emergencies). This includes, but is not limited to, picking up or launching a fallen vehicle, helping to steady a vehicle, giving water to a driver, picking up dropped parcel items, etc. The penalty for receiving assistance will be 500 meters deducted from the total race distance for each occurrence.

In the event that assistance is provided to a vehicle after a fall or accident, if the condition of the driver is questionable a judge or course marshal may hold the vehicle for 60 seconds in lieu of the 500 meter penalty. During the 60 second wait, the judge or marshal shall ascertain that the driver is mentally and physical prepared to continue the race.

Note: This rule does not prohibit team members or spectators from checking on the condition of the driver after an accident. If necessary, assistance may be provided to extract an injured or disabled driver or move a disabled vehicle off the course.

*G) General Obstacles*

Course obstacles shall include:

- 1) A speed bump typical of a city street speed control device; speed bump added to course will have maximum height no more than 5 cm (1.97"), but speed bumps of typical size already present on course (e.g. permanent asphalt speed bump) may go over this specification.
- 2) A stop sign, requiring a vehicle to come to a complete stop, and hold for 3 seconds until signaled to proceed by the stop sign judge.

- 3) A tight hairpin turn of approximately 180 degrees with a maximum radius that does not exceed 8 meters (26.2 ft). Double hairpin turns are acceptable and encouraged if facilities permit.
- 4) A slalom section consisting of a series of tight turns as shown in Figure 2. Knocking a tennis ball off of a cone constitutes failure of the obstacle.
  - a. Passing is permitted in the slalom, but due to increased safety concerns (e.g. potential for instability, tight spaces, tight turns, etc.) passing must be done with the utmost caution and will be penalized heavily if an unsafe pass is made. Teams must make certain that there is clear room to pass and also alert the team being passed with the use of a horn or bell.
- 5) A section of rumble strip which will simulate a washboard road or cobblestone street. This will likely be constructed of 1.9cm x 8.9cm (1"x4") boards lying flat running perpendicular to the track on 66cm (26") centers and will be wide enough for two lanes of traffic through the obstacle.

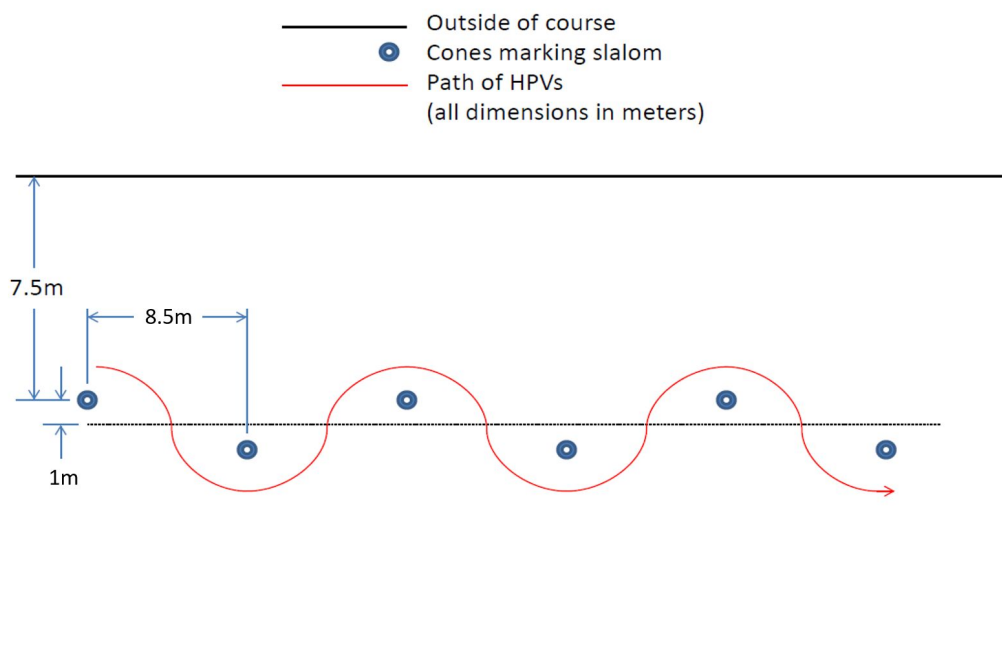

**Figure 2: Slalom course (Note: actual layout subject to limitations of venue)**

If possible, all obstacles shall be located on the course such that at least one continuous kilometer is obstacle-free, but obstacles will be spread out enough to reduce traffic in and around obstacles if possible. Please note that actual obstacles used at the competitions may differ from described above due to venue limitations.

#### H) Venue Specific Challenges

Additional challenges and obstacles may be implemented at specific venues to challenge teams to develop further in the areas of practicality and robustness. Each host, in conjunction with the ASME judging staff, will select which specific challenges will be implemented; 1 to 3 venue specific challenges will be chosen for each HPVC. Some challenges will not be announced until as late as the drivers meeting immediately before the race, but other challenges, which require substantial design accommodations, will be announced well ahead of time to allow for adequate preparation.

1) *Hillclimb- Low Grade (<5%)*

A low grade hill climbing challenge will be included as a portion of the full endurance lap and teams must complete the obstacle on every lap. Teams will be notified of the hill and approximate grade during the drivers meeting.

2) *Hill Climb- Steep Grade (≥5%)*

A steeper grade hillclimbing challenge will be an independent obstacle from a standard endurance lap. On a lap where a team elects to perform a hillclimb challenge; teams will proceed around the course as usual until they approach the entrance to the hillclimb obstacle. Teams will then enter the approach chute, gradually slow to a stop at the hillclimb start line and then proceed up the incline. Teams will continue upwards, reach the apex indicated by a marker, descend in a slow and controlled manner (walking speed), and finally come to a complete stop at the base of the hill before rejoining the course.

Teams must complete one hillclimb for every 10 kilometers of track length completed. The 10 kilometers distance would be measured in nearest number of laps. For example, one hillclimb must be completed within six 1.5 kilometers laps. Only one hillclimb may be completed per lap, but hillclimb laps may be completed back to back, or spread out at team's discretion. For each team at least two different drivers must complete a hillclimb challenge.

Teams that cannot climb the incline in the usual manner in which they operate their vehicle may push their vehicle up the hill, assuming that they follow all other competition rules to complete the challenge. No outside assistance is allowed in making upward or downward progress on the hill.

Teams will be notified of the Steep Hill Climb challenge and approximate grade no later than 90 days prior to the event.

3) *Low Light Endurance Challenge*

The endurance race may be held in the evening or early morning at such a time that natural light is limited or nonexistent. Depending on the venue, artificial lighting such as street lights may or may not be present. This challenge is specifically intended to emphasize the lighting and visibility design needs for practical human powered transportation.

- This is a strictly additive challenge and all other rules and challenges of the endurance event are still valid
- All vehicles will be **required** to run a 300 lumen or greater white headlight and a 10 lumen or greater red taillight
- Safety judging will include special emphasis on lighting and visibility. Failure to meet safety, visibility, or lighting requirements during safety judging will disqualify a team from the low light endurance event.
- Vehicles may be pulled from the event if for any reason they are deemed unsafe for the low light conditions. This includes the loss of a headlight or taillight.
- The low light endurance challenge will be announced no later than 90 days prior to the event

#### 4) *Weighted Trailer Challenge*

The trailer challenge will be **an optional challenge** that teams may elect to complete on a single lap of their endurance race. Teams will be required to stop, connect a weighted trailer, and complete a full lap. The bonus assessed will be based on the amount of weight elected to tow.

All teams intending to attempt the weighted trailer challenge must design onto their vehicle a trailer mount ring. The mounting ring shall be mounted horizontally and located at the rearmost location of their vehicle 350mm above the ground. The ring must measure 2 inch ID and 1/4" gauge such as ring 3564T26 offered on McMaster-Carr. The event hosts will provide a trailer that attaches to the trailer mounting ring. The unloaded trailer will have a mass of approximately 11.5kg (25.4lbm) and teams can elect to add up to 45.2kg (100lbm) in increments of 11.3kg (25lbm).

If a team decides to complete the weighted trailer pull lap they will proceed around the course as usual until reaching the trailer installation area. Teams will enter the queue, decelerate, and stop at the line specified on the ground. The vehicle operator will then exit the vehicle, indicate to the judges how much desired additional weight will be added, retrieve the weighted trailer and attached it to their vehicle to be towed around the following lap. Upon successfully hitching their vehicle to the trailer, operators can ingress and proceed around the lap as normal. After completion of the single lap and arrival at the trailer installation area, drivers will exit the vehicle, unhitch the trailer and place it back in its station. The driver can then ingress and rejoin the race as normal. If teams cannot complete the weighted lap they are responsible to return the trailer to the trailer installation area as quickly as possible by any means possible; this includes the aid of additional team members. Teams that attempt the challenge, but do not return the trailer in a reasonable time (approximately 3 times an average lap time) will be penalized.

Once teams successfully return with the weighted trailer the judges will determine the appropriate bonus. Bonus reward laps will be added on to each team's total distance at the end of the race and be calculated as follows:

$$\text{Rewarded Additional Laps} = 2 * \frac{\text{total weight of trailer towed (kg)}}{\text{maximum weight of trailer}}$$

$$\text{maximum weight of trailer} = \text{weight of unloaded trailer} + 45.2(\text{kg})$$

Only a limited number of teams will be able to perform the weighted trailer challenge at a time therefore delays due to a waiting queue are possible. Teams are encouraged to plan their attempt accordingly.

The weighted trailer challenge will be announced no later than 90 days prior to the event

#### 5) *Parcel Pickup and Delivery*

A parcel pickup and delivery station shall be provided on the course. Each team is required to pick up and deliver a parcel for every 10 kilometers of track length. The 10

kilometer distance would be measured in nearest number of laps. For example, each team must pick up and deliver a parcel once every six 1.5 kilometer lap. At least two drivers must make a pickup or delivery. Teams start the race with a parcel. At the first parcel stop, the initial parcel is deposited with a parcel clerk who will record the time and vehicle number. Subsequently, parcels are alternatively picked up or dropped off. After dropping the parcel on the fifth stop, the parcel pickup/delivery requirement will be met. Teams may choose when to stop, and stops are permitted throughout the event. Note that delays due to a waiting queue are possible. Teams are encouraged to plan stops accordingly. Failure to complete five stops with at least two drivers shall result in a one lap penalty for each missed stop. If all five stops are made by the same driver the team will be penalized one lap. Damage to parcels will be assessed at the completion of the five drop offs and appropriate penalties will be made at that time (See IX).

When entering the parcel pickup area, vehicles must park in designated parking spots. These spots will be oriented perpendicular to the direction of the course. Drivers must fully dismount their vehicle, retrieve and secure the parcel, and re-mount their vehicle. The orientation of the parking spot will require vehicles to either back into or out of the spot. Note that, as always during the endurance race, drivers are allowed to push their vehicle. Vehicle entry/exit may not be undertaken in active traffic.

The parcel will be a standard sized 38x33x20 cm (15”h x 13”w x 8”d) reusable grocery bag containing items determined by the host (mass not to exceed 5.5 kg).

The parcel pickup and delivery challenge will be announced no later than 90 days prior to the event.

#### 6) *Bypass Challenge*

The bypass challenge is an optional challenge that teams can complete during each lap. No points are awarded for completing this obstacle, but if completed it may reduce lap time. The bypass challenge allows bypassing a section of the course (~10% - 25% of course length) by traversing an especially challenging obstacles. Obstacles could include, for example, loose terrain (sand, gravel, mud, uneven terrain, etc) or steep slopes (curb, drop offs, potholes, etc).

Teams must approach and exit the obstacle at safe speed and yield to both vehicles currently attempting the challenge and oncoming vehicles when re-entering the course.

Teams that cannot complete the Bypass Challenge in the usual manner in which they operate their vehicle may push their vehicle, assuming that they follow all other competition rules to complete the challenge. No outside assistance is allowed.

The endurance bypass challenge will be announced no later than 90 days prior to the event.

*I) Lap Counting Process*

Laps will be counted by the competition judges and an Assistant Lap Counter provided by each team.

- (a) The judges will record laps of all teams in sequence as the official record of the race.
- (b) *Assistant Lap Counters* Each competing team must provide one assistant lap counter as a scoring assistant to count and record laps. This record will serve as a back-up to correlate the official lap count. Lap counters will be provided with a lap counting sheet to record:
  - (i) The **time-of-day** each lap is completed using time from their own watch; counters need not be synchronized between teams and/or judges
  - (ii) The driver's gender and identity**

No score will be tabulated for any team that does not provide an assistant lap counter.

*J) Driver/Stoker Requirements*

- (a) Minimum distance for any driver: the number of laps nearest 5 km or 30 minutes (whichever occurs first).
- (b) Maximum distance for any driver: the number of laps nearest 20 km.
- (c) Each team must have **at least one driver of each gender**.
- (d) A team may include any number of drivers as long as the distance-per-driver requirements are met.
- (e) All laps by an individual driver must be continuous – that is, all drivers must complete their laps in sequence, uninterrupted by any other driver, and may not ride in that event further.
- (f) A driver's distance or time may be cut short due to injury, vehicle disablement, or end of scheduled race time. There will be no penalty as a result of scheduled race ending prior to present occupant's completion of minimum distance. Otherwise the Head Judge must rule that the driver is indeed unable to continue in order to avoid penalty.
- (g) All laps not completed to these requirements will be subject to the lap requirement violation penalty
- (h) For multi-driver (i.e. tandem) vehicles, the minimum distance also applies to same-gender crews. At least one male-only crew and one female-only crew must complete the minimum distance. After that mixed-gender crews are permitted and each individual driver must complete minimum distance. If a multi-driver vehicle is operated by a single team member that will count as the minimum laps for their gender.

*K) Judging Area*

The lap counting and judging area will be adjacent to the start/finish area. It will be off limits to everyone except competition officials and the assistant lap counters.

*L) Drivers' Meeting*

All drivers who will participate in the Endurance Event must attend the mandatory Drivers' Meeting for that event. Drivers' meetings will take place approximately 45 minutes prior to the scheduled start of the race. The meeting will clarify operating procedures and signals and will identify course features, hazards, and landmarks.

Any team that is not represented at this meeting will normally not be permitted to participate in the event; in cases of unavoidable absence, the team may file an appeal with the competition judges, whose decision regarding participation will be final.



*M) Course Practice*

The road course will be opened by the Head Judge for practice and will remain open at his/her sole discretion. All vehicles practicing on the course must be operated in the intended direction of the course and in a safe manner and with extreme caution, particularly when entering the pit area or any other areas congested with participants, officials, or spectators.

All drivers operating a vehicle on or adjacent to the course, on competing vehicles or otherwise must wear helmets meeting the approved standards for the competition.

*N) Signals*

Flags will be used by competition officials as follows:

<u>Flag Color</u>	<u>Usage</u>
Green	Start event
Red	Stop event
Yellow or Orange	Proceed with caution, beware of hazards, no passing without sufficient passing lane
Black	Proceed directly to pits: problem with vehicle, rule infringement, or penalty assessment
White	Less than 10 minutes remaining in the race
Black & White Checkered	Event completed, proceed to pit area

Each Course Marshal will be supplied with a yellow or orange flag with which to signal caution in the event of an accident. During a caution flag, passing will be allowed when sufficient space is available to pass, but under no circumstances will unsportsmanlike conduct, cutting off another HPV, or contacting another HPV be permitted, and violating this rule will result in a conduct violation.

All other flags will be held in the judging area. As described, a green flag will signal that the event is underway, the black flag is used to indicate that a HPV is to go directly to the pits on their next lap, the white flag indicates 10 minutes left in race time, and the checkered flag indicates the end of the race. A red flag displayed at the race start will indicate that a restart is necessary, and all vehicles should proceed by their most direct path to the starting area. A red during the event requires that all vehicles stop at the earliest safe opportunity. At the end of the race a 'clean up vehicle' will display a red flag to indicate that the race has ended and is not to be overtaken. The vehicles should then return to the pit area as the course will then be closed.

*O) Disabled Vehicles*

The first concern following any accident is the safety of the driver. Once it has been determined that the driver is not injured, disabled vehicles must be removed from the course as soon as possible. In the event of an injury, no person should take any action that might increase the risk associated with the injury. In the case of injury, only on-site paramedics, ambulance workers or licensed medical professionals should tend to the injured.

Disabled vehicles must be removed from the course at the nearest safe exit. Disabled vehicles may be returned to the pit area by the driver and/or team members by safely removing the vehicle from the course and wheeling or carrying it to the pit area.

Course workers may assist with the removal of vehicles from the course, as necessary in the interest of safety. Primary responsibility, however, remains with the respective team. Non-emergency blockage of the course by a disabled vehicle may result in the assessment of a penalty.

Traffic will be controlled in the area of a disabled vehicle by the Course Marshals or by other competition officials, who will oversee the clearing of the course and signal the resumption of normal competition.

Disabled vehicles that have been removed from the course and repaired must re-enter the course either at the point of removal or at some point that it had passed between that point and the starting line on that same lap. That is, no vehicle will advance its position on the course as the result of a disablement. Re-entering vehicles must yield the right-of-way to vehicles on the course.

*P) Fouls and Penalties*

Fouls and penalties for the endurance event are described in the general fouls and penalties Section VII.

*Q) Interruptions*

The Endurance Event will normally run continuously. However, obstruction of the course, an emergency, hazardous weather, or other conditions may require a delay or premature termination of the event. The need for—and extent of—any such delay or termination will be evaluated by the competition judges, with the Head Judge making the final determination.

If the event is interrupted and a restart is required, the restart order will recreate, as nearly as possible, the order of vehicles at the time of the interruption.

*R) Termination*

The endurance event shall be run for 2.5 hours. At that time, all vehicles still in the competition will be permitted to finish the lap they are currently on. A "sweep" vehicle will enter the course and complete one lap. The sweep vehicle shall not pass any operable competing vehicles on the course, nor shall any competing vehicles pass the sweep vehicle. At the completion of the lap by the sweep vehicle, the event will be declared complete.

When the official race clock reads elapsed time of 2:20, the white flag shall be placed on prominent display near the judge's area, and will remain there until a race time of 2:30. At that time, the white flag shall be replaced with the black and white checkered flag.

*S) Scoring*

Vehicle rank in the endurance event is based on average speed minus penalties. The formula for average speed is:

$$V_{average} = \frac{(Number\ of\ Laps\ Completed - Lap\ Penalties) \times (Lap\ Length) - (Distance\ Penalties)}{(Finish\ Time + Time\ Penalties)}$$

Points are awarded based on each individual vehicle's average speed compared to the fastest average speed.

$$Points = \frac{V_{average}}{V_{maximum\ average}} \times Maximum\ Event\ Points$$

Where the Maximum Event Points is the point value for the event, specified in Section IX.

## VIII. General Fouls and Penalties

Throughout the competition the Head Judge and the competition judges will determine whether a foul has occurred and the extent of any assessed penalty (which may include disqualification from an event or from the competition). The responsible team will be notified as soon as possible of an infraction and any resultant penalty by the competition judges.

Penalties for fouls (including but not limited to examples below) will be assessed as follows:

- **Equipment violations**
  - Penalty
    - Require a pit stop to remedy the violation
  - Example
    - Failure to meet equipment requirements, including the proper display of vehicle numbers
- **Safety violations**
  - Penalty
    - Sprint- Require a pit stop to remedy the violation and speed/time for that run rejected
    - Drag- Require a pit stop to remedy the violation and up to 5% penalty in final event score
    - Endurance- Require a pit stop to remedy the violation and subtraction of one or more laps from the team's total lap count
  - Example
    - Such as entering the course without a proper helmet or seat belt
- **Lap requirement violations**
  - Penalty
    - Deduction of one lap for each improper lap
  - Example
    - Failure to meet minimum or maximum driver lap requirements
    - This includes **not meeting the minimum number of single gender laps**. For each lap missed, one lap will be subtracted from the total number completed
- **Illegal start assistance on course**
  - Penalties
    - Sprint- speed/time for that run rejected
    - Drag- Up to 25% penalty in final event score
    - Endurance- Deduction of 500 meters from total distance
- **Conduct violations:**
  - Penalty
    - Sprint- speed/time for that run rejected
    - Drag- Up to 25% penalty in final event score
    - Endurance
      - *First violation:* A minimum of a 15-second delay in the pit area. No work may be performed and no driver changes may be made during this stop.
      - *Second violation:* A minimum of a 60-second delay, with the same stipulations as above.
      - *Third violation:* Disqualification from the event
  - Example- Conduct violations include but are not limited to

- Obstruction of a vehicle by a competing team or by a spectator
- Foul driving, whether intentional or unintentional
  - Including an unsuccessful or dangerous pass in the slalom
- **Poor sportsmanship** or an activity that fosters unfair competition
- **Failure to complete an obstacle:**
  - Penalty
    - Deduction of 500 meters from total distance per infraction
    - OR repeat the failed obstacle
  - Example
    - Failure to stop at stop sign, complete the slalom, hairpin turn, quick turn, improper entry or exit of HPV at parcel stop, knocking any tennis balls off of cones, etc.
- **Damaging or loss of parcel:**
  - Penalty
    - Deduction of a maximum of 1,500 meters from total distance depending on severity of damage

Violations and penalties will be at the sole discretion of the Head Judge and the competition judges. Penalty appeals may be filed in accordance with specified protest procedures.

Drafting is expressly permitted as long as there is no interference with other vehicles.

**IX. Overall Scoring**

Overall Score Scores from Design Event, Speed Event, and Endurance Event will be combined to determine the overall standing of the competition.

The formula for combining the scores is:

$$\text{Overall Score} = \sum \text{Event Scores}$$

The maximum event points are:

<b>Competition Event</b>	<b>Maximum Points</b>
Design Event	50
Male Speed Event	12.5
Female Speed Event	12.5
Endurance Event	25
Total Score	100

In the case of a tie in the overall point count, the order of finish in the Design Event will determine the overall finish for all vehicles.

**X. Announcement of Results and Awards**

*A) Announcement of Results*

The judges will post the results of each event of the competition as soon as possible after the completion of the respective event and validation of the collected data.

*B) Presentation of Awards*

The awards presentation will be held after the completion of the competition's final event.

*C) Competition Awards*

Competition awards shall be given as follows:

Overall 1st Place:	Trophy and cash prize
Overall 2nd Place:	Trophy and cash prize
Overall 3rd Place:	Trophy and cash prize

Design Event	1 <sup>st</sup> + cash prize, 2 <sup>nd</sup> and 3 <sup>rd</sup> place trophies
Men's Speed Event	1 <sup>st</sup> + cash prize, 2 <sup>nd</sup> and 3 <sup>rd</sup> place trophies
Women's Speed Event	1 <sup>st</sup> + cash prize, 2 <sup>nd</sup> and 3 <sup>rd</sup> place trophies
Endurance Event	1 <sup>st</sup> + cash prize, 2 <sup>nd</sup> and 3 <sup>rd</sup> place trophies

Cash prize amounts will be posted on the competition websites.

Overall winner must participate, complete minimum requirements and score points in all events to be eligible for monetary awards.

Minimum requirements are valid non-zero scores in the Design Event, Male Speed Event, Female Speed Event and Endurance Event.

*D) Other Awards*

Teams will be recognized and awarded trophies for significant achievements during the course of the competition and the winners will be selected by teams voting. Voting will take place virtually during the final day of the competition and must be completed by the end of the final race. The details for the means of voting will be announced at the final drivers meeting. These awards include but are not limited to the following:

Sportsmanship	Special Achievement
Team Spirit	Perseverance
Innovation	Best Rookie Team
Craftsmanship	

Additional awards may be suggested or provided by the judges, host, the teams involved or others. Such awards are encouraged in the spirit of the competition; however all such awards must be approved by the competition judges.

*T) Review and Modification of Results*

If an error or discrepancy is determined in the final results, it will be addressed by the competition judges as quickly as possible. To assure scoring accuracy is maintained, the competition judges will expedite every effort to resolve errors and reserves the right to review the results for up to 48 hours after the official awards ceremony to ensure all scores are accurate and final.

## **XI. Clarification and Modification of Rules**

### *A) Clarification and Modification of the Rules*

These rules may be modified by the Competition Judges as necessary to maintain the competition as a challenging and rewarding experience for engineering students. No changes by any party shall be made without the written consent of the Global Chief Judge. Questions or recommended changes should be referred to the Global Chief Judge.

### *B) Global Chief Judge and Head Judges*

The Global Chief Judge and Head Judges of the ASME Human Powered Vehicle Challenge each serve a three year term and together maintain the competition rules.

Global Chief Judge: Karan Desai

Asia Pacific Head Judge: Farhan Javed

North America East Head Judge: Jeremy Mikesell

North America West Head Judge: Peter Aumann

South America Head Judge: Rene Martinez

### *C) Questions and Comments About the Rules*

Questions and comments about the rules must be posted on the HPVC forum here:

<https://groups.google.com/forum/#!forum/asme-hpvc>



## XII. Appendix 1 Design Event Judge's Score Sheet

<b>Design Report Evaluation</b>	<b>100</b>	
<b>General</b>	<b>5</b>	<b>Evaluated based on report</b>
<b>1 Form 6</b>	1	Form 6 completed and attached to front of report (V.F.1)
<b>2 Title Page</b>	1	Title page information correct and complete (V.F.2)
<b>3 3-View Drawing</b>	1	3-View drawing, in accordance with ASME Y14.5 and related standards such as ASME Y14.24 and ASME Y14.3
<b>4 Abstract</b>	2	Abstract included, correct length, clear, concise, and informative. This should be page 1
<b>Design</b>	<b>15</b>	<b>Evaluated based on report</b>
<b>1 New Design</b>	2	2 - Teams must demonstrate that the entry is a new design (not just a new frame or fairing) completed during the current academic year, or not HPVC entry for last 2 years 1 - Some new elements (frame, fairing, etc.) or no HPVC entry for last year 0 - Similar to previous year's entry
<b>2 Design Methodology</b>		
Design Objective	1	Provide clear design objectives and goals for project. (Hint: "To Win" or "To do better than last year" are not acceptable objectives)
Background research	1	Include supporting research and review of prior art. Provide background information to justify your objectives, mission, design approaches, and design concepts. Background research should include specific information found/used to aid in design and development of the HPVC, but should not include your teams general competition history. Appropriate background research can include information found on HPV development, aerodynamics, HPV standards (such as ISO or Federal), competitive vehicles, etc. Cite references as appropriate.
Prior Work	1	Clearly document any design, fabrication, or testing that was not completed in the current academic year. If teams reuse work from previous years and it is not listed here teams will be assessed a penalty for reusing content.
Organizational Timeline	1	Include an organizational timeline or Gantt chart showing project scheduling and completion
Design Criteria/PDS	1	Provide well established design criteria and product design specifications
Alternatives and Evaluation	2	Present alternative designs that were considered using concept improvement and selection techniques
Structured Design Methods	1	Document use of established design methodologies, including, but not limited to QFD, Decision Matrices, etc. How did you choose features of your design with respect to your specifications and requirements?
Description	1	Describe the final vehicle design, making generous use of drawings and figures. Describe how the vehicle can be practically used, what environmental conditions were addressed and components and systems were selected or designed to meet the objectives.
<b>3 Discretionary Points</b>	4	Discretionary points based on overall thoroughness, quality, accuracy, and approach
<b>Analysis</b>	<b>25</b>	<b>Evaluated based on report</b>
<b>1 Rollover/Side Protection System</b>		Per RPS requirements
Top Load Modeling	1	Clearly and accurately describe constraints, idealizations, load path from driver to ground, etc.
Top Load Results	2	Clearly describe and interpret results, score depends on results and perceived validity of results. Target load is to be applied and deflection value is to be clearly documented as result. 0: Maximum total elastic deflection equal to or greater than 7.6 cm (3.0 in); 1: 6.4 cm (2.5 in); 2: 5.1 cm (2.0 in) or less
Side Load Modeling	1	Clearly and accurately describe constraints, idealizations, load path from driver to ground, etc.
Side Load Results	2	Clearly describe and interpret results, score depends on results and perceived validity of results. Target load is to be applied and deflection value is to be clearly documented as result. 0: Maximum total elastic deflection equal to or greater than 6.4 cm (2.5 in); 1: 5.1 cm (2.0 in); 2: 3.8 cm (1.5 in) or less
<b>2 Structural Analytical Calculations</b>		Demonstrated appropriate and correct use of numerical computational tools such as FEA, CFD, etc.
Objectives	1	Clear objective for the analysis
Analysis Case Definitions	1	Clearly identify and describe analysis cases, include rationale for each
Modeling	1	Clearly and accurately describe constraints, idealizations, use of symmetry, etc.
Results	2	Clearly describe and interpret results
Design Modifications	1	Demonstrate how results were used to modify and improve the design
<b>3 Aerodynamics</b>		
Aero Device Incorporated	1	All entries are required to have an aerodynamic device incorporated into their design (makeshift items, false claims, and claims such as reclined driver position contributes to aero will not be granted credit)
Alternatives Evaluated	1	Must evaluate several alternatives in a trade study
Chosen Design Substantiated	1	Must substantiate chosen aero device through analysis
<b>4 Cost Analysis</b>		
	2	Tabulated cost summary of prototype included. Include all actual expenditures and capital costs, but do not include student labor.
<b>5 Other Analyses</b>		Vehicle handling, stability, steering, suspension kinematics & dynamics, optimizations, and other analyses
Objectives	1	Clear objective for the analysis
Analysis Case Definitions	1	Clearly identify and describe analysis cases, include rationale for each
Results	1	Clearly describe and interpret results
Design Modifications	1	Demonstrate how results were used to modify and improve the design
<b>6 Discretionary Points</b>	4	Discretionary points based on overall thoroughness, quality, accuracy, and approach

<b>Testing</b>		<b>25</b>	<b>Evaluated based on report and presentation</b>
<b>1</b>	<b>Rollover/Side Protection System</b>		Per RPS requirements
	Top Load Testing Setup	1	Test method clearly described, appropriate, and scientific
	Top Load Testing Results	2	Clearly describe and interpret results, score depends on results and perceived validity of results. Increasing load is to be added to RPS until maximum deflection is reached and then load achieved is to be clearly stated as the result. 0: Less than 1780N (400 lbf); 1: 1780-2670N (400-599 lbf); 2: ≥2670N (600 lbf)
	Side Load Testing Setup	1	Test method clearly described, appropriate, and scientific
	Side Load Testing Results	2	Clearly describe and interpret results, score depends on results and perceived validity of results. Increasing load is to be added to RPS until maximum deflection is reached and then load achieved is to be clearly stated as the result. 0: Less than 890N (200 lbf); 1: 890-1330N (200-299 lbf); 2: >1330N (300 lbf)
<b>2</b>	<b>Developmental Testing</b>		Physical testing to develop or verify design, usually conducted prior to final vehicle construction
	Objective & Methodology	1	Clear objective for the experiment. Methodology clearly described, appropriate, and scientific
	Results and Discussion	1	Data is reported and presented clearly, with appropriate discussion (interpretation, error sources, uncertainty, etc.)
	Statistical Analysis	1	Data is analyzed and presented clearly, with appropriate statistical analyses (t-test, ANOVA, regression, etc.) and measures (mean and standard deviation, confidence intervals, p-value, etc.)
	Conclusions	1	Conclusions and recommendations stated clearly. Results should be quantitative where possible and include applicable statistical analyses (mean, standard deviation, student T test, etc.)
	Design Modifications	1	Demonstrate how testing results used to modify or improve the design
	Comparison with PDS and Analysis	1	Test results clearly compared with analysis results and product design specifications
	Comprehensiveness	1	Extent of developmental testing: 0: few experiments/little significance on design, 1: many experiments/significant effect on design
<b>3</b>	<b>Performance Testing</b>		Physical testing (often conducted on final vehicle) to evaluate and optimize performance
	Objective & Methodology	1	Clear objective for the experiment. Methodology clearly described, appropriate, and scientific.
	Results and Discussion	1	Data is reported and presented clearly, with appropriate discussion (interpretation, error sources, uncertainty, etc.)
	Statistical Analysis	1	Data is analyzed and presented clearly, with appropriate statistical analyses (t-test, ANOVA, regression, etc.) and measures (mean and standard deviation, confidence intervals, p-value, etc.)
	Conclusions	1	Conclusions and recommendations stated clearly. Results should be quantitative where possible and include applicable statistical analyses (mean, standard deviation, student T test, etc.)
	Design Modifications	1	Demonstrate how testing results used to modify or improve the design
	Comparison with PDS and Analysis	1	Test results clearly compared with analysis results and product design specifications
	Comprehensiveness	1	Extent of developmental testing: 0: few experiments/little significance on design, 1: many experiments/significant effect on design
<b>4</b>	<b>Discretionary Points</b>	<b>5</b>	Discretionary points based on overall thoroughness, quality, accuracy, and approach
	<b>Safety</b>	<b>20</b>	<b>Evaluated based on safety inspection and safety video</b>
<b>1</b>	<b>Rollover/Side Protection System</b>		
	Installation & Design	1.5	Rollover/Side protection system installed and functional
	Consistent with RPS rule	1.5	RPS design and fabrication appears consistent with rules
	Prevents bodily contact with ground	1	RPS must prevent the drivers appendages and head from contacting the ground in the event of a crash where the HPVC falls over or inverts
<b>2</b>	<b>Safety Harness</b>	<b>2</b>	Seat belt installed correctly and appears to meet rules
<b>3</b>	<b>Steering System</b>	<b>1.5</b>	No excessive play or looseness, correct installation, apparent stability, etc.
<b>4</b>	<b>Braking System</b>	<b>1.5</b>	Inspection shows brake levers & calipers/brake assemblies are rigidly mounted, cables are tight, pads have ample thickness and pads make full contact with rim/disk. HPV must pass braking performance test within one or two attempts for full points
<b>5</b>	<b>Sharp Edges, Protrusions, Pinch Points</b>	<b>2</b>	No sharp edges or protrusions on fairing, frame or components. No hazardous pinch points, especially near spoked wheels, chains, sprockets, etc. (Subtract points for serious hazards)
<b>6</b>	<b>Other Hazards</b>	<b>1</b>	No other obvious hazards
<b>7</b>	<b>driver's Field of View</b>	<b>1</b>	Driver should have more than 180 degrees of visibility
<b>8</b>	<b>Safety Accessories</b>		
	Bell/Horn	1	Audible signal device installed and operational
	Taillight	1	Red Taillight visible 150 meters to the rear, installed and operational
	Headlight	0.5	White headlight installed and operational, visible 150 meters to the front, installed and operational
	Side reflectors	0.5	Red, amber, or similar colored reflectors on each side of vehicle properly installed
	Rear view mirrors	0.5	Mirror(s) installed providing the driver with views to the rear of the vehicle
<b>9</b>	<b>Additional Safety Features</b>	<b>1.5</b>	An additional safety feature(s) are incorporated specific to their design (beyond required safety features)
<b>10</b>	<b>Discretionary Points</b>	<b>2</b>	Discretionary points based on the quality and thoroughness of design to maximize HPVC safety (based on report and safety inspection)
	<b>Aesthetics</b>	<b>10</b>	<b>Evaluated based on state of vehicle at safety inspection</b>
	Overall impression of vehicle	3	Overall impression
	Quality of craftsmanship	3	Craftsmanship (welds, joints, assembly, etc.) is professional and attractive
	Quality of custom parts	2	Team-fabricated and custom parts look professional and of high quality
	Quality of Frame/Fairing Finish	2	Exterior finish and decoration quality is neat, attractive, and professional (frame and/or fairing)

**XIII. Appendix 2: Protest Form**

	<p><b>PROTESTS Form</b> <b>Human Powered Vehicle Challenge</b> <b>Competition Location:</b> _____ <b>Competition Date:</b> _____</p>
<p><b>*** This is <u>NOT</u> a required form. It may be used <u>only if</u> a team is filing a protest during a competition ***</b> <b>Additional details can be found in the Rules, Section II.G.</b> <b>***</b></p>	

**Protests**

Protests may be made in accordance with the rules of the ASME Human Powered Vehicle Challenge. This protest format may be used or not used at the discretion of the team or individual presenting the protest. If this format is not used, the information outlined herein should be included in whatever format is used.

Any intent to protest must be announced within 15 minutes of the causative action, and the written protest must be submitted within 30 minutes of this announcement. Oral protests will not be honored.

Date: \_\_\_\_\_ Protestor’s Vehicle No: \_\_\_\_\_  
Protesting School: \_\_\_\_\_  
Other Vehicle(s) Involved (if applies): \_\_\_\_\_

Event during which protested action occurred: \_\_\_\_\_  
Nature of protest (e.g., rule violation, error in scoring, etc.): \_\_\_\_\_

Description of incident/statement of protest (may be entered or continued on separate page)

---

---

---

---

---

---

---

---

---

---

Judges Action:

---



---



---



---



---



---



---



---



---



---



---



---



---



---



---



---

XIV. Appendix 3: Safety Exemption Request Form

	<p><b>Requested Exemptions to the Safety Certification</b> <b>Human Powered Vehicle Challenge</b> <b>Competition Location:</b> _____ <b>Competition Date:</b> _____</p>
<p><b>*** This is <u>NOT</u> a required form. It is to be used <u>only if</u> a registrant/team is requesting an exemption to the safety certification ***</b> <b>Any request for exemptions from specific safety requirements must be submitted in writing using this form to the competition Head Judge at <a href="mailto:hpvcasme@gmail.com">hpcasme@gmail.com</a></b> <b><u>NOTE: You have up to 10 days following your vehicle registration for this submission</u></b></p>	

School: \_\_\_\_\_

Vehicle/Team Name: \_\_\_\_\_

Vehicle Number (if applicable): \_\_\_\_\_

Requestor's Name/Team Captain's \_\_\_\_\_

I request the following exceptions to the safety certification, and I have included a brief justification for that/those request(s):

**XV. Appendix 4: ASME Report Cover Page & Vehicle Description Form**

	<p><b>ASME Report Cover Page &amp; Vehicle Description Form</b> <b>Human Powered Vehicle Challenge</b> Competition Location: _____ Competition Date: _____</p>
<p><i>This required document for <u>all</u> teams is to be incorporated in to your Design Report. Please Observe Your Due Dates; see the ASME HPVC website and rules for due dates.</i></p>	

**Vehicle Description**

University name:

Vehicle name:

Vehicle number:

Vehicle configuration:

Upright  
Prone

Semi-recumbent  
Other (specify)

Frame material:

Fairing material(s):

Number of wheels:

Vehicle Dimensions (m)

Length:

Width:

Height:

Wheelbase:

Weight Distribution (kg)

Front:

Rear:

Total Weight (kg):

Wheel Size (m)

Front:

Rear:

Frontal area (m<sup>2</sup>):

Steering (Front or Rear)

Braking (Front, Rear, or Both):

Estimated Coefficient of Drag:

Vehicle history (e.g., has it competed before? where? when?):

---

---

---

## XVI. Appendix 5: Suggested Reference Material

Below are reference documents helpful in HPV design and construction. If your team references any of these sources please ensure they are properly cited in your report.

### Vehicle Design

1. ["The Recumbent Trike Design Primer"](https://pdfs.semanticscholar.org/5ee5/84368629fdc7ad69a3adf63da2c8e90de9f4.pdf) (Rickey Horwitz, 2010). Basic pedal-powered tricycle design considerations, online.
2. ["Engineer to Win"](https://www.amazon.com/Engineer-Win-Carroll-Smith/dp/B011MBDQOM) (Carroll Smith, 2010). Racing car design, paperback.
3. ["Race Car Vehicle Dynamics"](https://www.amazon.com/Race-Car-Vehicle-Dynamics-Premiere/dp/1560915269) (William Milliken, 1994)

### Materials

1. ["Racer's Encyclopedia of Metals, Fibers & Materials"](https://www.amazon.com/Encyclopedia-Materials-Motorbooks-International-Powerpro/dp/0879389168) (Forbes Aird, 1994). Paperback.
2. ["Competition Car Composites"](https://www.amazon.com/Competition-Car-Composites-Practical-Handbook/dp/1845849051) (Simon McBeath, 2016). Composites design & fabrication handbook, hardcover.

### Human Power and Bicycle

1. ["Sheldon Brown's Bicycle Technical Info"](https://www.sheldonbrown.com/) (Sheldon Brown). Bicycle design and reference guides
2. ["Design of Human Powered Vehicles"](https://www.amazon.com/Design-Human-Powered-Vehicles-Mark-Archibald/dp/0791861104) (Mark Archibald, 2016). Extensive HPV discussion, hardcover.
3. ["Bicycling Science"](https://www.amazon.com/Bicycling-Science-Press-Gordon-Wilson/dp/0262731541) (David Gordon Wilson, 2004). Broad introductory cycling resource, paperback.
4. ["The Biomechanics of Force and Power Production in Human Powered Vehicles"](https://digitalcommons.brockport.edu/cgi/viewcontent.cgi?article=1100&context=pes_facpub) (Danny Too, Gerald Landwer). Factors affecting power production via recumbent pedaling, online.
5. ["Biomechanics of Cycling"](https://www.degruyter.com/downloadpdf/j/ssr.2010.xix.issue-1-2/v10237-011-0012-0/v10237-011-0012-0.pdf) (Borut Fonda & Nejc Sarabon). Literature review of cycling biomechanics, online.
6. ["HPVC Safety Dos and Don'ts"](https://community.asme.org/hpvc/w/wiki/13014.educational-resources.aspx#Safety-Dos-Donts) (Mark Archibald, 2016). HPV safety best practices.
7. ["Lords of the Chainring"](https://www.amazon.com/Lords-Chainring-William-Patterson-ebook/dp/B006W417OG) (William Patterson, 2012). Technical theory of the handling qualities of bicycles and motorcycles. Basis of a university course on single track vehicle design.

If you have any suggestions for additional reference material please post it on the HPVC Question Forum linked in Section I.D